

TWS Bluetooth Earphone Charging Box SOC integrated with 500mA charger and 200mA discharger

1. Features

- **Discharge**
 - ◇ 200mA Synchronous Boost Conversion
 - ◇ Up to 95%@5V/200mA discharge efficiency of synchronous switch
 - ◇ Built-in power path management supports charging and discharging at the same time
- **Charge**
 - ◇ Max 500mA linear charger, charging current can be customized
 - ◇ Adjusts charging current automatically to adapt to different load capacity adapters
 - ◇ Supports 4.20V, 4.30V 4.35V, 4.40V batteries. Standard product 4.20V, other voltages need to be customized
- **Battery indicators**
 - ◇ Supports 2/1 LED battery indicator
- **Output enable**
 - ◇ Support output enable control, can be matched with Hall device
- **Low-power dissipation**
 - ◇ Automatically detect earphone plugged-in/plugged-out/charger-end, Automatically enter standby mode
 - ◇ Standby power consumption up to 10uA minimum
- **Simplified BOM**
 - ◇ Built-in power MOS, only a few peripheral devices are needed in the complete charging and discharging scheme
- **Multiple protection, high reliability**
 - ◇ Output: over current and short circuit protection
 - ◇ Input: over voltage protection and Battery over charged protection

- ◇ Over temperature protection
- ◇ Vin pin can withstand up to 12V(transient voltage)
- ◇ ESD 2KV

2. Applications

- TWS Bluetooth Earphone Charging Box

3. Description

IP5416 is a multi-functional power management SOC for total solution on TWS Bluetooth Earphone Charging Box. It integrates with 5V boost converter, lithium battery charging management and battery level indicators.

IP5416 is highly integrated with abundant functions, support boost with one single inductor, which makes the total solution with minimized-size and low-cost BOM.

The synchronous 5V-boost system of IP5416 provides rated 200mA output current with conversion efficiency up to 95%, can support low-cost inductors and capacitors.

IP5416's linear charger supplies max 500mA charging current. With the change of IC temperature and input voltage, IP5416 can automatically adjust the charging current.

IP5416 can detect the TWS earphone plug-in/plug-out in the Charging Box independently. While the earphone is put in the Charging Box, it enters the discharging mode automatically. When the earphone is fully charged, the Charging Box automatically enters the sleep state, and the standby current can be reduced to 10uA.

IP5416 can support 2/1 LED battery indicator.

IP5416 is packaged with SOP8.

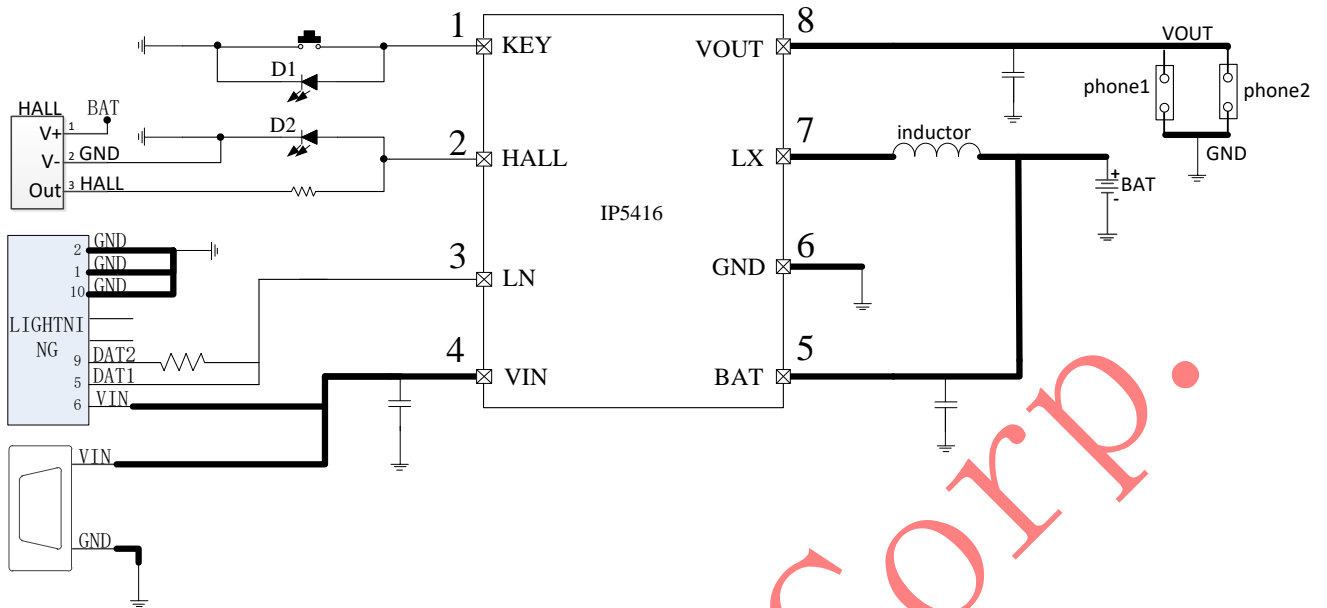

Figure1 IP5416 Simplified Application Diagram

4. Pin Definition

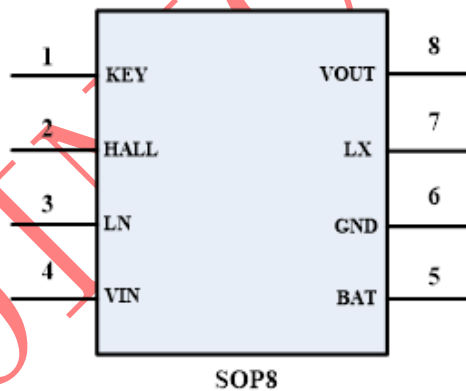

Figure2 IP5416 Pin Assignments

Pin Num	Pin Name	Description
1	KEY	Key,reused as drive LED1 function
2	HALL	HALL switch output signal
3	LN	Lightning decoding pin
4	VIN	5V input pin
5	BAT	Battery charging pin, connected to the battery positive
6	GND	Ground
7	LX	DCDC switch node
8	VOUT	Boost 5V output

5. IP5416 IC Products List

IC part No.	Charging Current	Standby VOUT voltage	LED Mode	Key Mode	Light load shut down/light off Time	HALL	lightning
IP5416_BT	300mA	2.4V	2	Single start Single close	8S	Support	Support
IP5416_CK	300mA	5V	2	Single start Single close	8S	Support	Support

6. IP Series TWS Charging IC Products List

	IC Part No	LED Mode	Charging Current	Light-Load time	Key mode	Light - Load Current to enter	auto-wakeup supporting	always-5V supporting	Minimum order quantity
IP5303T series	IP5303T_BT_200MA	1/2	200mA	32s	single statr,double close	5mA	yes	no	4K
	IP5303T_BT_500MA	1/2	500mA	32s	single statr,double close	5mA	yes	no	4K
	IP5303T_BT_500MA_S_NAT	1/2	500mA	32s	single statr,double close	5mA	no	no	4K
IP5305T series	IP5305T_BT	1/2/3/4	1A	32s	single statr,double close	5mA	yes	no	4K
	IP5305T_BT_500MA	1/2/3/4	500mA	32s	single statr,double close	5mA	yes	no	4K
	IP5305T_BT_300MA	1/2/3/4	300mA	32s	single statr,double close	5mA	yes	no	4K
	IP5305T_BT_8S	1/2/3/4	1A	8s	single statr,double close	5mA	yes	no	4K
	IP5305T_BT_8S_300MA	1/2/3/4	300mA	8s	single statr,double close	5mA	yes	no	4K
IP5403 series	IP5403_CK10_5M	4	500mA	36s	single statr,no key close	10mA	no	yes	4K
	IP5403_CK10_5M_D1D2	1/2	500mA	36s	single statr,no key close	10mA	no	yes	4K
	IP5403_CK10_2M	4	200mA	36s	single statr,no key close	10mA	no	yes	4K
	IP5403_CK10_2M_D1D2	1/2	200mA	36s	single statr,no key close	10mA	no	yes	4K
	IP5403_BT10_5M	4	500mA	36s	single statr,no key close	10mA	no	no	4K
	IP5403_BT10_5M_D1D2	1/2	500mA	36s	single statr,long close	10mA	no	no	4K
	IP5403_BT10_2M	4	200mA	36s	single statr,long close	10mA	no	no	4K
	IP5403_BT10_2M_D1D2	1/2	200mA	36s	single statr,long close	10mA	no	no	4K

7. Absolute Maximum Ratings

Parameter	Symbol	Value	Unit
Input Voltage Range	V_{IN}	-0.3 ~ 12	V
Junction Temperature Range	T_J	-40 ~ 150	°C
Storage Temperature Range	T_{stg}	-60 ~ 150	°C
Thermal Resistance (Junction to Ambient)	θ_{JA}	90	°C/W
ESD (Human Body Model)	ESD	2	KV

*Stresses beyond these listed parameter may cause permanent damage to the device.
 Exposure to Absolute Maximum Rated conditions for extended periods may affect device reliability.

8. Recommended Operating Conditions

Parameter	Symbol	Min.	Typ.	Max.	Unit
Input Voltage	V_{IN}, V_{BUS}	4.5	5	5.8	V
Operating Temperature	T_A	0	--	70	°C

*Device performance cannot be guaranteed when working beyond these Recommended Operating Conditions.

9. Electrical Characteristics

Unless otherwise specified, $T_A=25^\circ\text{C}$, $L=2.2\mu\text{H}$

Parameter	Symbol	Test Conditions	Min.	Typ.	Max.	Unit
Charging System						
Input Voltage	V_{IN}	$V_{BAT}=3.7\text{V}$	4.5	5	5.8	V
Input under voltage	V_{INUV}	$V_{BAT}=3.7\text{V}$		4.5		V
Input Over Voltage	V_{INOV}	$V_{BAT}=3.7\text{V}$	5.6	5.8	6.0	V
Constant Charge Voltage	$CV_{4.2V}$	4.2V battery	4.15	4.20	4.24	V
	$CV_{4.30V}$	4.3V battery	4.28	4.30	4.34	V
	$CV_{4.35V}$	4.35V battery	4.33	4.35	4.4	V
	$CV_{4.4V}$	4.4V battery	4.38	4.40	4.44	V
Charge Stop Current	$I_{vinstop}$	$V_{IN}=5\text{V}$		30	40	mA
Charge Current	I_{VIN}	$V_{IN}=5\text{V}, V_{BAT}=3.7\text{V}, I_{set}=300\text{mA}$	275	300	325	mA
Trickle Charge Current	I_{TRKL}	$V_{IN}=5\text{V}, V_{BAT}=2.7\text{V}, I_{set}=300\text{mA}$		30		mA
Trickle Charge Stop Voltage	V_{TRKL}		2.9	3	3.1	V

Boost System						
Battery Operation Voltage	V_{BAT}		3.1	3.7	4.4	V
Low Power Shutdown Voltage	V_{BATLOW}	IOUT=200mA	3.0	3.1	3.2	V
DC Output Voltage	V_{OUT}	VBAT=3.7V @0A	5.05	5.15	5.25	V
		VBAT=3.7V @200mA	5.0	5.05	5.15	V
Output Voltage Ripple	ΔV_{OUT}	VBAT=3.0V~4.4V @200mA	50	100	150	mV
Boost Output Current	I_{Vout}	VBAT=3.0V~4.4V	0	200	300	mA
Boost Overcurrent Shut Down Threshold	I_{shut}	VBAT=3.0V~4.4V	0.4		0.8	A
Light load shutdown threshold	I_{PLOUT}	VBAT=3.7V, The load current of both headphones must be less than I_{plout} to shut down.		5		mA
Load Over current Detect Time	T_{UVD}	Duration of output voltage under 4.2V		30		ms
Load short circuit Detect Time		Duration of output voltage under Battery voltage		20		us
Control System						
Switch Frequency	fs	Discharge switch frequency	0.9	1.1	1.3	MHz
PMOS On Resistance	r_{DSON}			450		mΩ
NMOS On Resistance					550	
Battery Input Standby Current 1	I_{STB1}	VIN=0V,VBAT=3.7V,VOUT=2.4V/0V		11		uA
Battery Input Standby Current 2	I_{STB2}	VIN=0V,VBAT=3.7V,VOUT=5.0V		12		uA
LED Driving Current	I_{LED}		4	6	8	mA
Light Load Shut Down Detect Time	T_{loadD}	Load current less than I_{PLOUT}	6	8	10	s
Short Press On Key Wake Up Time	$T_{OnDebounce}$		100		500	ms
Long Press On Key Wake Up Time	$T_{Keylight}$		2		3	s
Thermal Shut Down Temperature	T_{OTP}	Rising temperature	130	140	150	°C
Thermal Shut Down Hysteresis	ΔT_{OTP}		30	40	50	°C

10. Function Description

System Diagram

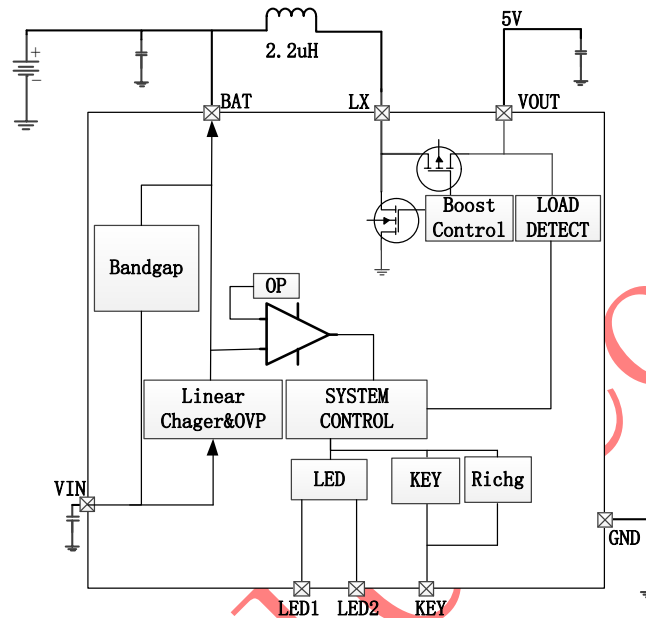

Figure3 IP5416 Internal System Diagram

Boost

IP5416 integrates a boost dc-dc converter with 5V/200mA output. To avoid large rush current causing device failure, it is built in overcurrent, short circuit, overvoltage and over temperature protection function, ensuring the reliability and stability of system operation. According to the IC temperature, IP5416 boost system can intelligently adjust output current, ensuring the IC temperature is below the set temperature.

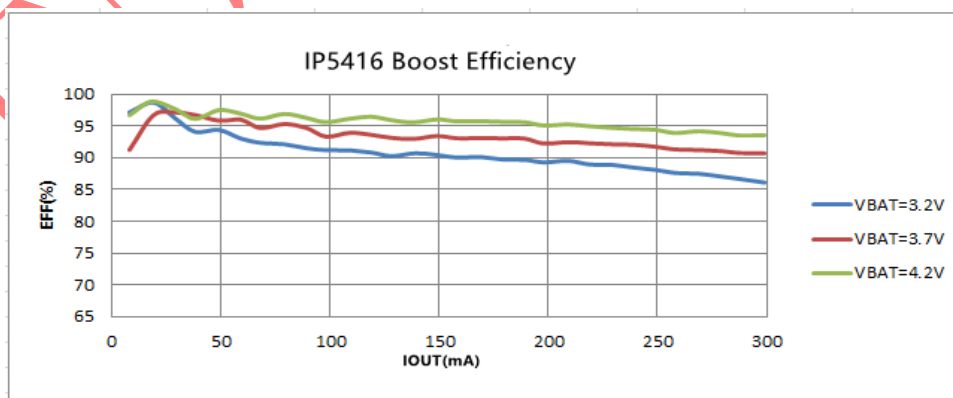

Figure4 IP5416 Boost Efficiency Curve

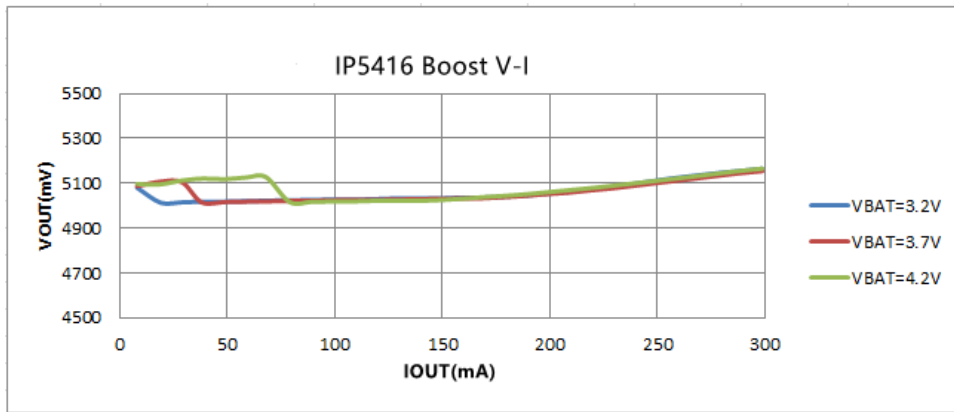

Figure5 IP5416 Boost Output V-I Curve

Charge

IP5416 integrates a linear lithium battery charger. When the battery voltage is less than 3V, precharge with $20\text{mA} + I_{\text{set}} * 5\%$. when the battery voltage is greater than 3V, enter constant current CC charging. when the battery voltage is close to 4.2V/4.3V/4.35V/4.4V, enter constant voltage charging.

IP5416 supports max 500mA linear charging, According to the IC temperature and input voltage, IP5416 can intelligently adjust charging current. I

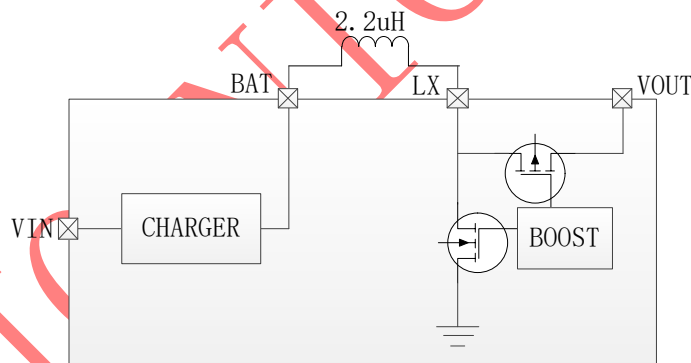

Figure6 IP5416 Power Path Diagram

Battery level display

IP5416 has a built-in power algorithm, which can accurately display the remaining battery power according to the cell capacity.

IP5416 can support 1/2LED battery indicator.

LED light display mode

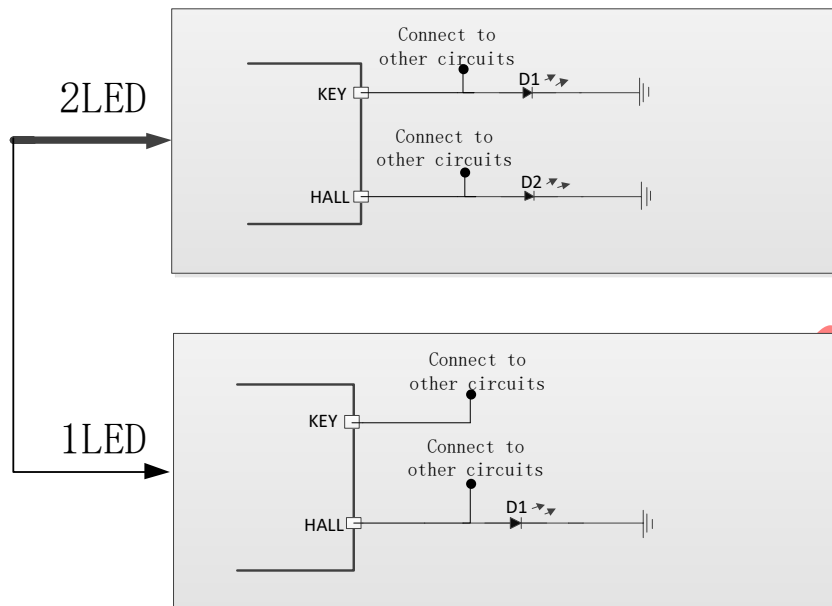

Figure7 LED Mode Selection Circuit

Note: IP5416 can't automatically identify 1/2 LED modes, 1/2 LED modes needs to be customized separately.

■ 2 LED Mode

	state	D1	D2
charge	charging	0.5Hz blink	off
	full	on	off
discharge	discharging	off	on
	low	off	1Hz blink

■ 1 LED Mode

	state	D1
charge	charging	0.5Hz blink
	full	on
discharge	discharging	on
	low	1Hz blink

KEY Function

IP5416 support single start, single close

Short press (pressed time in range of 100ms~2s): turn on the battery level display LED and BOOST output.

Long press (pressed time longer than 2s): No response

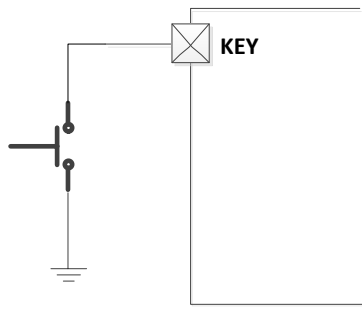

Figure8 Key circuit

Hall function

IP5416 can identify the change of output level of hall device and control the output, when earphone charging box is open, the earphone automatically turns on and connects back to the mobile phone.

- The signal level types of Hall devices supported by IP5416 standard models are: when the earphone charging box is opened, hall outputs high level, when the earphone charging box is closed, hall outputs low level.

When hall level is high: VOUT output 0V, earphone starts automatically.

When hall level is low: VOUT output 5V, earphone is charging.

- For other types of Hall devices, please contact the injoinic technical support department

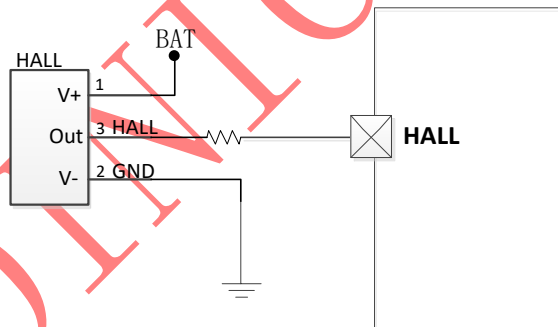

Figure9 HALL circuit

Light load standby instructions

Hall changes from high level to low level (Earphone charging box close), IP5416 automatically enters the discharging mode to charge the earphone, when the earphone is fully charged, IP5416 automatically enters the sleep state.

When the earphones are charged end, IP5416_BT series will enter standby mode and the VOUT output will change to 2.4V.

When the earphones are charged end, IP5416_CK series will enter standby mode and the VOUT output will change to 5V.

Hall changes from low level to high level (Earphone charging box open), IP5416 automatically close output and plug-in/plug-out detection.

11. Typical Application Diagram

Total solution of IP5416 charging Box is merely realized by passive devices of inductors, capacitors and resistors. The value of R1 / R2 in the figure can be selected by the customer according to the brightness of the required lamp.

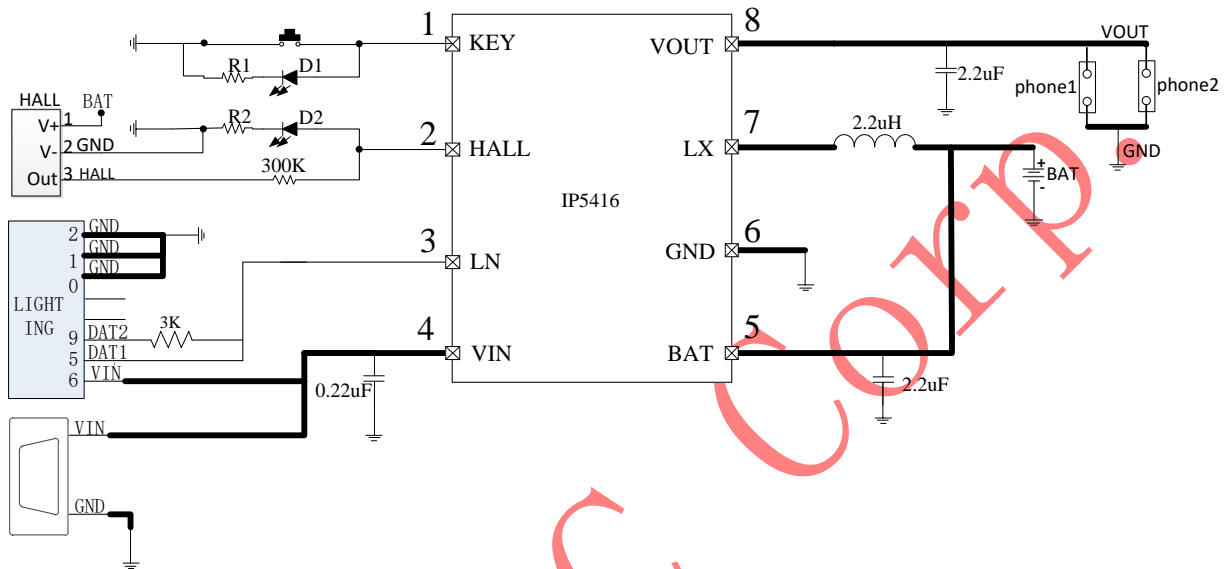

Figure10 2LED Mode Typical Application Diagram

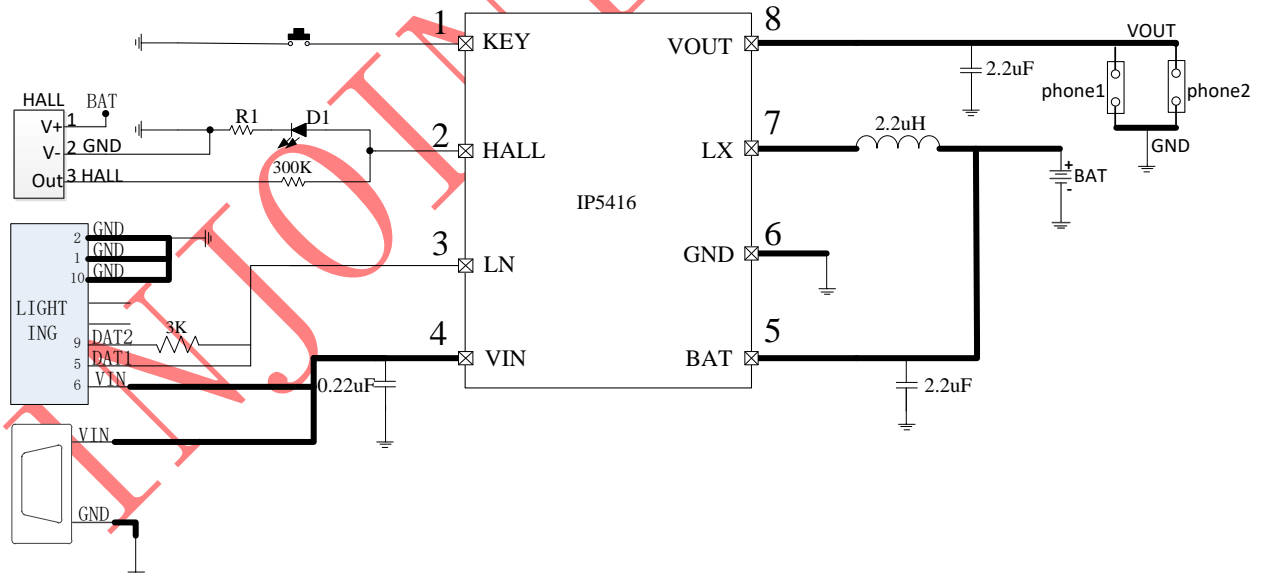
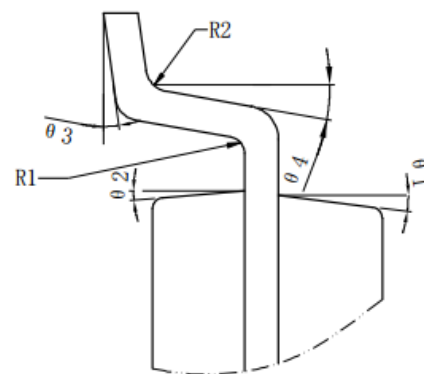
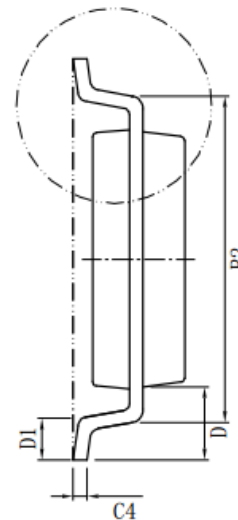
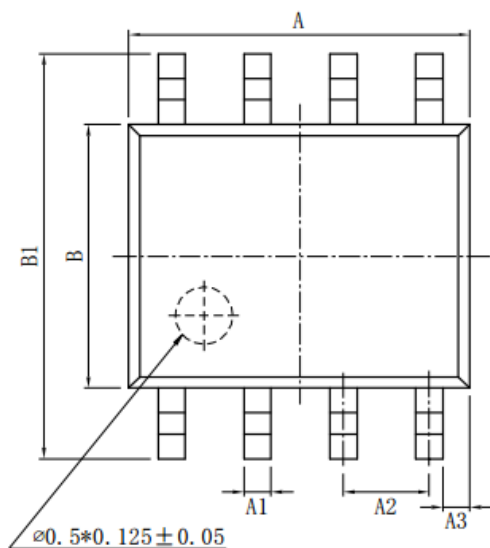

Figure11 1LED Mode Typical Application Diagram

12.Package



mark	size	min (mm)	max (mm)	mark	size	min (mm)	max (mm)
A		4.80	5.00	C3		0.05	0.20
A1		0.356	0.456	C4		0.203	0.233
A2		1.27TYP		D		1.05TYP	
A3		0.345TYP		D1		0.40	0.80
B		3.80	4.00	R1		0.20TYP	
B1		5.80	6.20	R2		0.20TYP	
B2		5.00TYP		θ 1		17° TYP4	
C		1.30	1.60	θ 2		13° TYP4	
C1		0.55	0.65	θ 3		0° ~ 8°	
C2		0.55	0.65	θ 4		4° ~ 12°	



13.Mark description



Note:

- 1、  --Injoinic Logo
- 2、 IP5416 --Part Number
- 3、 XXXXXXXX --Manufacture number
- 4、  --PIN1 location

INJOINIC

IMPORTANT NOTICE

INJOINIC TECHNOLOGY and its subsidiaries reserve the right to make corrections, enhancements, improvements and other changes to its semiconductor products and services. Buyers should obtain the latest relevant information before placing orders and should verify that such information is current and complete. All semiconductor products (also referred to herein as “components”) are sold subject to INJOINIC TECHNOLOGY's terms and conditions of sale supplied at the time of order acknowledgment.

INJOINIC TECHNOLOGY assumes no liability for applications assistance or the design of Buyers' products. Buyers are responsible for their products and applications using INJOINIC TECHNOLOGY's components. To minimize the risks associated with Buyers' products and applications, Buyers should provide adequate design and operating safeguards.

Buyer acknowledges and agrees that it is solely responsible for compliance with all legal, regulatory and safety-related requirements concerning its products, and any use of INJOINIC TECHNOLOGY's components in its applications, notwithstanding any applications-related information or support that may be provided by INJOINIC TECHNOLOGY. Buyer represents and agrees that it has all the necessary expertise to create and implement safeguards which anticipate dangerous consequences of failures, monitor failures and their consequences, lessen the likelihood of failures that might cause harm and take appropriate remedial actions. Buyer will fully indemnify INJOINIC TECHNOLOGY and its representatives against any damages arising out of the use of any INJOINIC TECHNOLOGY's components in safety-critical applications.

Reproduction of significant portions of INJOINIC TECHNOLOGY's information in INJOINIC TECHNOLOGY's data books or data sheets is permissible only if reproduction is without alteration and is accompanied by all associated warranties, conditions, limitations, and notices. INJOINIC TECHNOLOGY is not responsible or liable for such altered documentation. Information of third parties may be subject to additional restrictions.

INJOINIC TECHNOLOGY will update this document from time to time. The actual parameters of the product may vary due to different models or other items. This document voids all express and any implied warranties.

Resale of INJOINIC TECHNOLOGY's components or services with statements different from or beyond the parameters stated by INJOINIC TECHNOLOGY for that component or service voids all express and any implied warranties for the associated INJOINIC TECHNOLOGY's component or service and is an unfair and deceptive business practice. INJOINIC TECHNOLOGY is not responsible or liable for any such statements.