

Fully-Integrated Power Bank System-On-Chip with 2.1A charger, 2.4A discharger

1 Features

- **Switch buck charger and boost**
 - ◇ 2.1A Synchronous switching charger and 5V 2.4A boost converter
 - ◇ Boost converter efficiency up to 95%
 - ◇ Switching charger efficiency up to 91%
 - ◇ Integrated power-path management, charging batteries and charging cellphones at the same time
- **Charger**
 - ◇ Adaptive charging current control, adaptive adapter output capability
 - ◇ Support 4.20/4.30/4.35/4.40V batteries
- **State of charge (SOC) indicator**
 - ◇ Integrated LED controller supports 4/3/2/1 LEDs as the SOC indicator
 - ◇ The battery power curve can be set to make the display lamp more uniform
- **Fully featured**
 - ◇ Support for external selection of other key methods
 - ◇ Integrated flashlight controller
 - ◇ Integrated cellphone plug-in and plug-out detector
- **Low power**
 - ◇ Smart load detector, switching to standby mode automatically
 - ◇ <100 μ A standby current
- **Ultra simplified BOM**
 - ◇ Integrated power FET, charging/boosting with a single inductor
- **Multiple protections, high reliability**
 - ◇ Output over-current, over-voltage, short-circuit protection
 - ◇ Input over-voltage, over-current, battery over-charge, over-drain, over-current protection
 - ◇ Thermal Shutdown
 - ◇ ESD 4KV, Vin transient pressure up to 18V
- **In-depth customization**
 - ◇ I2C interface for flexible and low cost customized solution
Custom Version :IP5306H_I2C

2 Applications

- Power bank, Portable Charger
- Mobile Phones, Smart Phones, Handheld Devices, Portable Media Player, Tablet

3 Description

IP5306H is a fully-integrated multi-function power management SoC. It integrates a boost converter, a Li battery charger management system and a battery state of charge indicate controller. It provides a turn-key solution for power bank and portable charger applications.

IP5306H high integration and rich features make the minimized component number in application. It can effectively downsize the application and lower the BOM cost.

IP5306 only needs a single inductor to realize step-down and step-up which provides 2.4A output current. Conversion efficiency to 93%. It can switch to standby mode at light load automatically. standby current drops to 100uA.

IP5306H synchronous switching charger provides 2.1A charging current. Its efficiency is up to 91%. It regulates the charging current by IC temperature and input voltage.

IP5306H integrates voltage based fuel gauge indication of 1/2/3/4 LEDs and flashlight function.

IP5306H is available in ESOP8

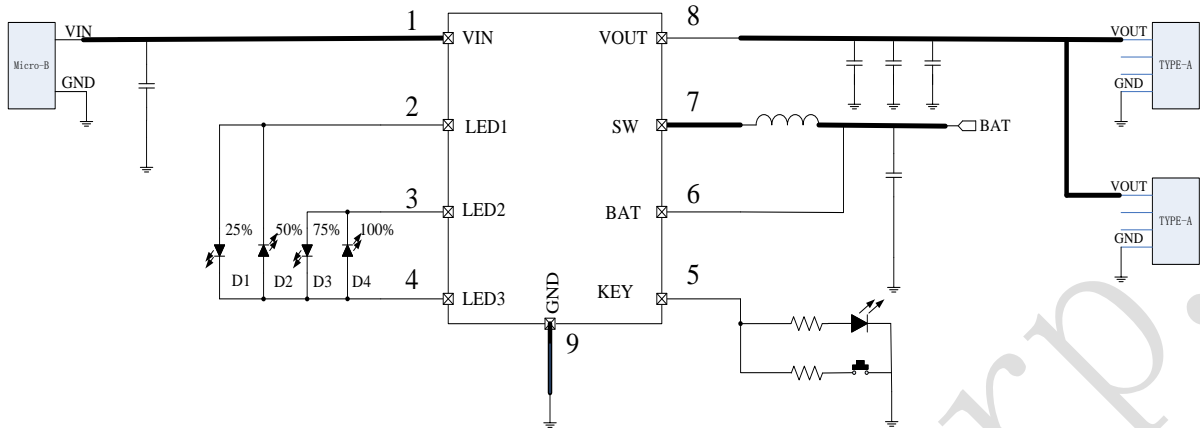

figure 1 Simplified application schematic (4 LEDs as the SOC indicator)

4 Pin Definition

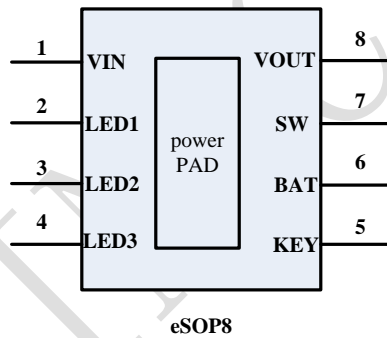

figure 2 IP5306H Pin Diagram

Pin Name	Pin Number	Pin Description
VIN	1	Charger 5V input pin
LED1	2	Battery indicator pin1
LED2	3	Battery indicator pin2
LED3	4	Battery indicator pin3
KEY	5	ON/OFF key input, multiplex torch lighting driver
BAT	6	Battery voltage sense pin
SW	7	DCDC switch node, connect inductor
VOUT	8	DCDC 5V output pin
PowerPAD		Connect to GND

5 Block diagram

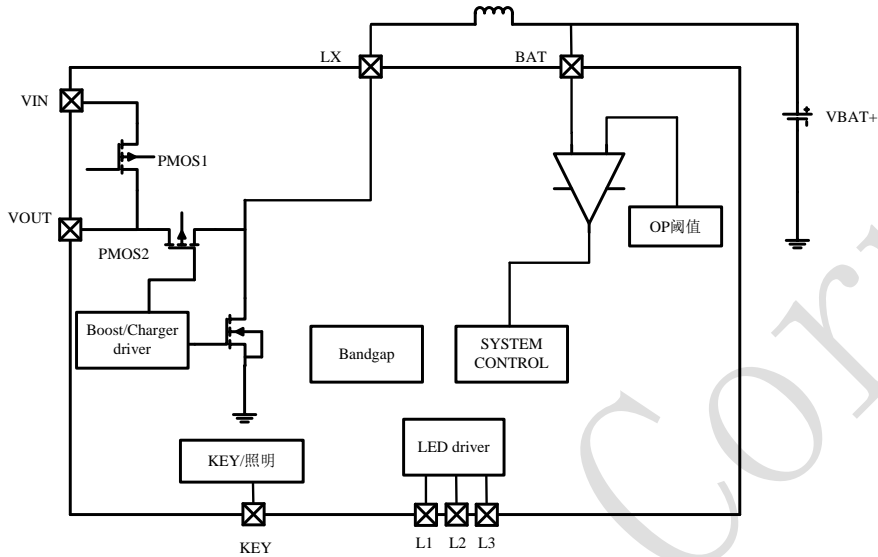
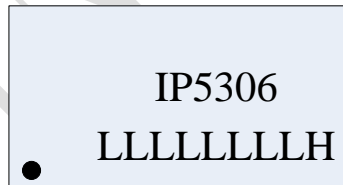

figure 3 IP5306H block diagram

6 Marking described

TOP Marking



IP5306: Part Number
 LLLLLLLL: Lot ID
 H: Combination with IP5306
 represents IP5306H product

figure 4 IP5306H 6 Marking described

7 The PartList of PowerBank SoC

IC Part No.	boost/charge		Main feature								Package	
	boost	charge	LED number	light	key	I2C	DCP	USB C	QC Certificate	PD3.0 /PPS	Package	Compatibility
IP5303T	1.0A	1.2A	1,2	√	√	-	-	-	-	-	ESOP8	PIN2PIN
IP5305T	1.0A	1.2A	1,2,3,4	√	√	-	-	-	-	-	ESOP8	
IP5306	2.4A	2.1A	1,2,3,4	√	√	√	-	-	-	-	ESOP8	
IP5306H	2.4A	2.1A	1,2,3,4	√	√	√	-	-	-	-	ESOP8	
IP5406T	2.4A	2.1A	1,2,4	√	√	-	-	-	-	-	ESOP8	
IP5407	2.4A	2.1A	1,2,4	√	√	-	-	-	-	-	ESOP8	
IP5207	1.2A	1.2A	3,4,5	√	√	-	√	-	-	-	QFN24	PIN2PIN
IP5209	2.4A	2.1A	3,4,5	√	√	√	√	-	-	-	QFN24	
IP5209U	2.4A	2.1A	3,4,5	√	√	√	√	-	-	-	QFN24	
IP5207T	1.2A	1.2A	1,2,3,4	√	√	√	√	-	-	-	QFN24	PIN2PIN
IP5189T	2.1A	2.1A	1,2,3,4	√	√	√	√	-	-	-	QFN24	
IP5189TH	2.1A	2.1A	1,2,3,4	√	√	√	√	-	-	-	QFN24	
IP5310	3.1A	3.0A	1,2,3,4	√	√	√	√	√	-	-	QFN32	
IP5506	2.4A	2.1A	Nixie Tube	√	√	-	-	-	-	-	ESOP16	
IP5508	2.4A	2.1A	Nixie Tube	√	√	-	√	-	-	-	QFN32	
IP5330	3.1A	3.0A	Nixie Tube	√	√	-	√	√	-	-	QFN32	
IP5566	3.1A	3.0A	1,2,3,4	√	√	-	√	√	-	-	QFN40	
IP5322P	18W	4.0A	1,2,3,4	√	√	√	√	-	√	-	QFN32	
IP5332	18W	4.0A	1,2,3,4	√	√	√	√	√	√	√	QFN32	
IP5328P	18W	4.0A	1,2,3,4	√	√	√	√	√	√	√	QFN40	
IP5358	22.5W	5.0A	Nixie Tube	√	√	-	√	√	√	√	QFN48	
IP5568	22.5W	5.0A	Nixie Tube	√	√	-	√	√	√	√	QFN64	

8 Absolute maximum ratings

Parameter	symbol	value	Unit
Port input voltage range	V_{IN}	-0.3 ~ 12	V
Junction temperature	T_J	-40 ~ 150	°C
Storage temperature	Tstg	-60 ~ 150	°C
Thermal resistance (from junction to ambient air)	θ_{JA}	50	°C/W
Human-body model (HBM)	ESD	4	KV

* Stresses beyond those listed under absolute maximum ratings may cause permanent damage to the device.

These are stress ratings only, and functional operation of the device at these or any other conditions beyond those indicated under recommended operating conditions is not implied. Exposure to absolute-maximum-rated conditions for extended periods may affect device reliability.

9 Recommended operation conditions

Parameter	symbol	MIN	Typical	MAX	Unit
Input voltage	V_{IN}	4.65	5	5.5	V
Load current	I	0	2.4		A
Operating ambient temperature	T_A	0	--	70	°C

* Beyond these operation conditions, the device's performance will not be guaranteed.

10 Electrical Characteristics

$T_A=25^\circ\text{C}$, $L=1\mu\text{H}$ unless otherwise noted

Parameter	symbol	Test condition	MIN	TYP	MAX	Unit
Charger system						
Input voltage	V_{IN}	V _{BAT} =3.7V	4.65	5	5.5	V
Input voltage OVP	V_{INOV}		5.51	5.6	5.8	V
Input voltage UVP	V_{INUV}		4.3	4.4	4.6	V
CV charge voltage	$CV_{4.2V}$	4.2V Battery Type	4.19	4.22	4.25	V
	$CV_{4.2V}$	4.30V Battery Type	4.29	4.32	4.35	V
	$CV_{4.35V}$	4.35V Battery Type	4.34	4.37	4.39	V
	$CV_{4.4V}$	4.4V Battery Type	4.39	4.42	4.45	V
stop charge current	I_{stop}	V _{IN} =5V	200	400	600	mA

Charge current	I_{VIN}	Current at the VIN path	1.8	2.1	2.3	A
Trickle charge current	I_{TRKL}	VIN=5v, BAT=2.7v	150	250	350	mA
Trickle charge stop voltage	V_{TRKL}		2.9	3	3.1	V
Recharge threshold	V_{RCH}		4.02	4.05	4.08	V
Charger safety timer	T_{END}		20	24	27	Hour
Boost system						
Battery operation voltage	V_{BAT}		3	3.7	4.4	V
Battery low protection voltage	V_{BATLOW}	IOUT=1A	2.9	2.95	3.05	V
Battery operation current	I_{BAT}	VBAT=3.7V, VOUT=5.0V, fs=500KHz	2	5	20	mA
DC-DC output voltage	V_{OUT}	VBAT=3.7V @0A	5.0	5.12	5.25	V
		VBAT=3.7V @2.4A	4.75	5	5.15	V
Output voltage ripple	ΔV_{OUT}	VBAT=3.7V, VOUT=5.0V, fs=500KHz	50	100		mV
Boost output current	I_{vout}		0	2.4	3.3	A
Boost output shutdown current	I_{OVP}	VBAT=3.7V	2.7	3.1	3.5	A
Load over-current detect timer	T_{UVD}	Output voltage continuously lower than 4.2V	10	30	50	ms
Load short-circuit detect timer	T_{OCD}	Output current continuously larger than 5A	100	150	200	us
Control system						
Switching frequency	f_s	Boost switching frequency	400	500	600	KHz
		Charger switching frequency	600	750	850	KHz
PMOS on resistance	r_{DSON}	VBAT=3.7V	30	35	45	mΩ
NMOS on resistance		VBAT=3.7V	20	25	35	mΩ
PMOS between VIN and VOUT on resistance	r_{DSON}	VIN=5V	70	80	90	mΩ
Input voltage OCP	I_{IDOC}	VIN=5V	2.5	3	3.5	A
Battery standby current	I_{STB}	VIN=0V, VBAT=3.7V		100		uA
LED lighting current	I_{light}		20	30	40	mA
LED indicator current	I_{L1}					
	I_{L2}		2	10	20	mA
	I_{L3}					

Load removal detect timer	T_{loadD}	Load current continuously lower than 45mA	25	32	44	s
Light load shutdown current	I_{plout}	VABT=3.7V	20	45	100	mA
Push-button wake-up timer	$T_{OnDebounce}$		70	100	500	ms
Push-button light-on timer	$T_{Keylight}$		2	2.5	3.5	s
Thermal shutdown	T_{OTP}	Rising temperature	125	140	150	°C
Thermal shutdown hysteresis	ΔT_{OTP}		30	40	50	°C

11 Function description

Charger

IP5306H integrates a synchronous constant-current and constant-voltage switching Li battery charger. When battery is below 3.0V, the charger is in trickle mode, and charging current is 100mA. When battery is above 3V, the charger turns to constant-current mode, and constant-voltage mode is used if battery voltage reaches 4.2V. When charge is over, recharge will begin if battery is below 4.1V.

IP5306H switching charger has a 750KHz switching frequency, and its maximum charging current is 2.1A, charging efficiency is up to 91%, shortening 3/4 charging time in comparison with the normal chargers.

Adaptive adapter charging current, support charging and discharging at the sametime. .

Boost

IP5306H integrates a 5V output step-up DCDC converter with 2.4A output capacity. It works at 500 KHz. When input battery voltage is 3.7V, its efficiency is 93% with the output of 5V/2A. Internal soft-start circuit prevents malfunction caused by starting inrush current. It integrate short-circuit, over-voltage, over-voltage protection, making the system stable and reliable.

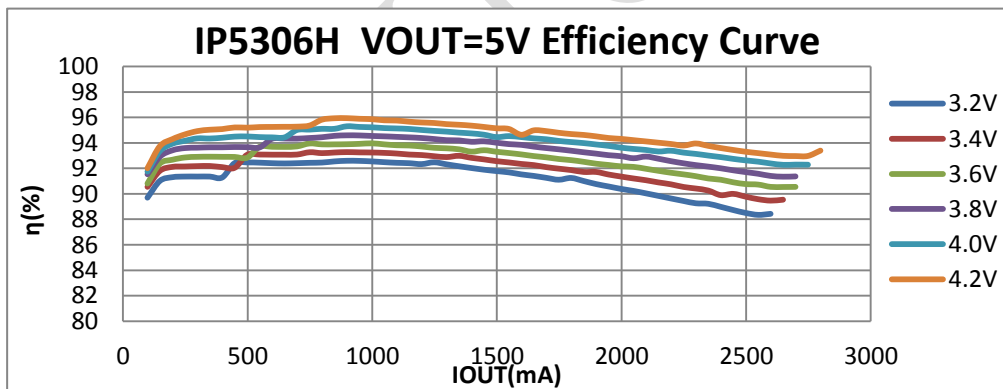

Figure 5 IP5306H VOUT=5V Efficiency Curve

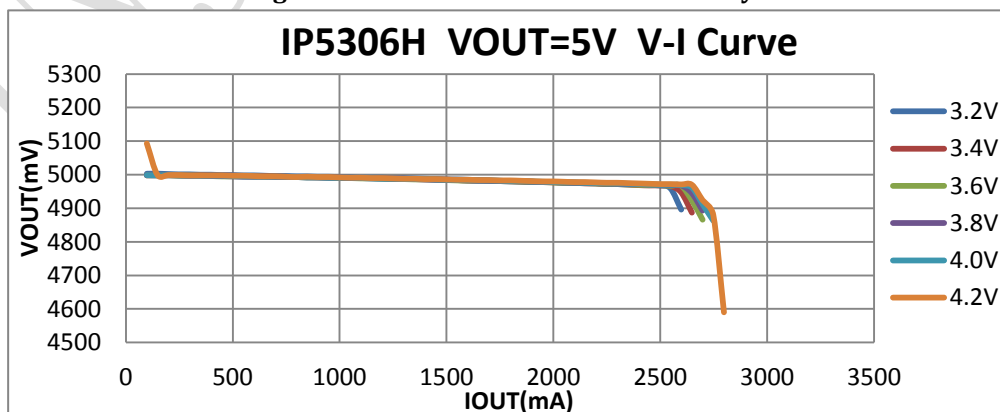

Figure 6 IP5306H VOUT=5V V-I Curve

State Of Charge (SOC) indication

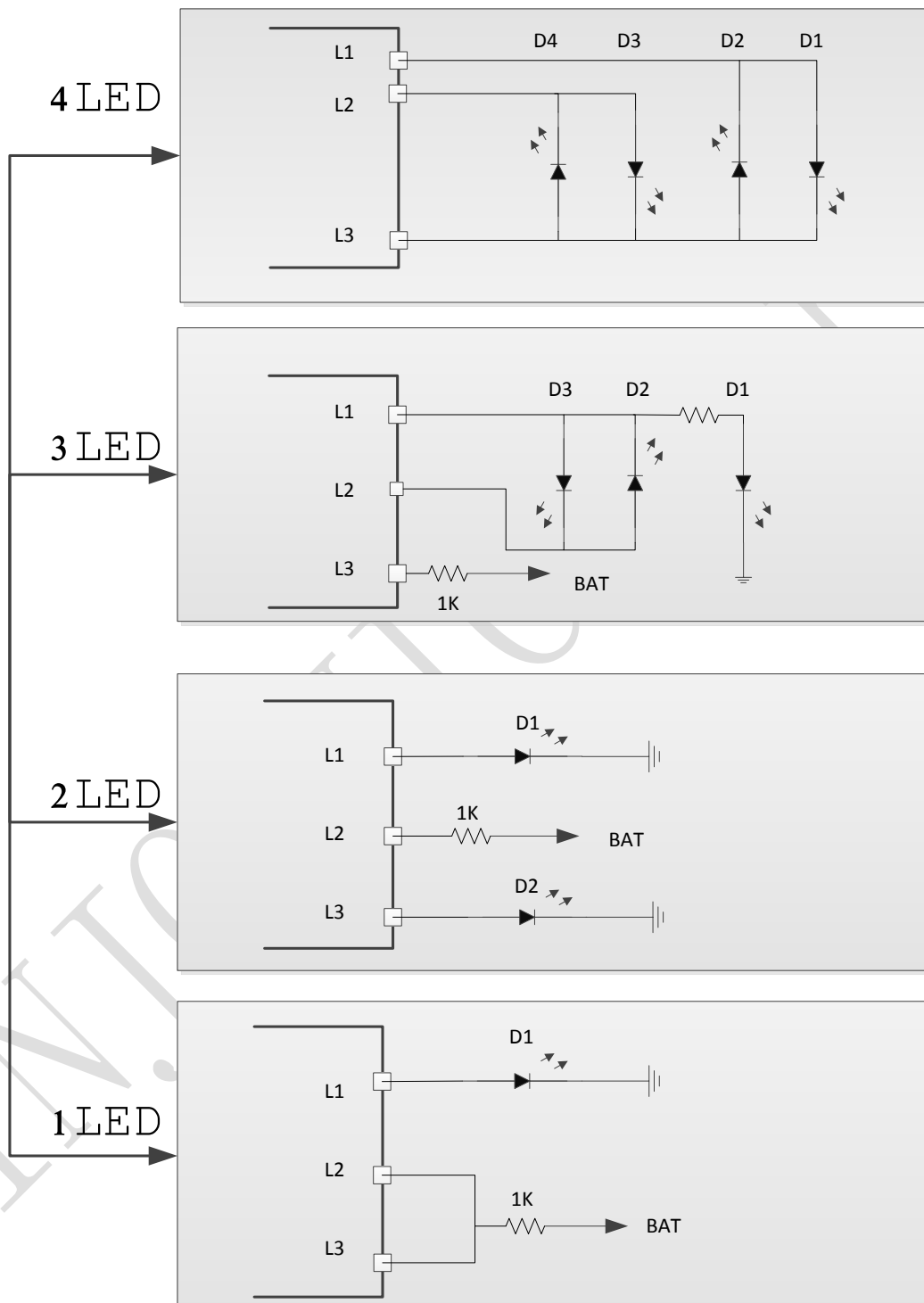

figure 7 4/3/2/1 LED PIN configuration

■ 4 LED mode

Discharging mode, 4 LEDs as the indicator

SOC (%)	L1	L2	L3	L4
$SOC \geq 75\%$	ON	ON	ON	ON
$50\% \leq SOC < 75\%$	ON	ON	ON	OFF
$25\% \leq SOC < 50\%$	ON	ON	OFF	OFF
$3\% \leq SOC < 25\%$	ON	OFF	OFF	OFF
$0\% < SOC < 3\%$	1Hz blink	OFF	OFF	OFF
$SOC = 0\%$	OFF	OFF	OFF	OFF

Charging mode 4 LEDs as the indicator

SOC (%)	L1	L2	L3	L4
Full	ON	ON	ON	ON
$75\% \leq SOC$	ON	ON	ON	0.5Hz blink
$50\% \leq SOC < 75\%$	ON	ON	0.5Hz blink	OFF
$25\% \leq SOC < 50\%$	ON	0.5Hz blink	OFF	OFF
$SOC < 25\%$	0.5Hz blink	OFF	OFF	OFF

■ 3 LED mode

The displays of 3 LEDs are similar to that of 4 LEDs. The corresponding SOC of each LED is presented in the following table.

	D1	D2	D3	D4
3 LEDs	33%	66%	100%	NA
4 LEDs	25%	50%	75%	100%

■ 2 LED Mode

	state	LED1	LED2
Charging	In charging	ON	OFF
	End of Charge	OFF	OFF
Boost	In discharging	OFF	ON
	Low Battery	OFF	Blink

■ 1 LED Mode

	state	LED1
Charging	In charging	Blink
	End of Charge	ON
Boost	In discharging	ON
	Low Battery	Blink

KEY\Key_mode selection

IP5306H can recognize short press or long press operation, PIN5 dangling when no buttons are required.

- Short press : pressed time in range of 100ms~2s
- Long press :pressed time longer than 2s
- No response on press time less than 70ms
- Double short buttons in a row within 1s will turn off boost output, power display and lighting LED

IP5306H support selects the key mode through external pin.(Only 4 LED mode and 3 LED mode are supported)

LED2 (pin 3) connects different resistors (R_{key}) to GND to select different key_modes. Key_modes multiplexes with LED2 display output.

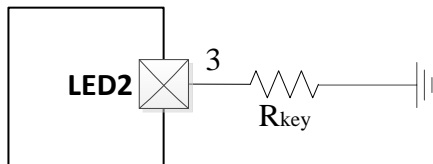

figure 8 Rkey circuit

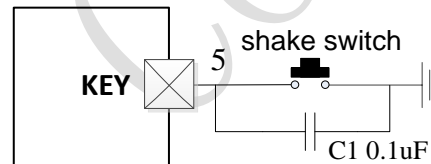

figure 9 shake switch circuit

RKEY	KEY function definition
20K	Short press: turn on Double short press in 1s: no definition Long press: turn on or turn off the lighting
43K	Short press: turn on Double short press in 1s: turn on or turn off the lighting Long press: no definition
75K	Short press: turn on Double short press in 1s: no definition Long press: no definition Support shake switch
100K	Short press: turn on.boost always on, Light load 32S turn off the LED Double short press in 1s: no definition Long press: turn on or turn off the lighting
NC	Short press: turn on Double short press in 1s: turn off Long press:turn on or turn off the lighting

VSET (Battery full voltage selection)

IP5306H supports 4.2v, 4.3v, 4.35v and 4.4v battery full voltage selection. (support all LED mode)
 LED1 (pin 2) connects different resistors (R_{vset}) to GND to select different battery full voltage. VSET multiplexes with LED1 display output.

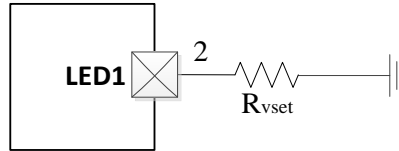

figure 9 VSET circuit

RVSET	Battery full voltage selection
NC	4.2V
43K 1%	4.3V
75K 1%	4.35V
100K 1%	4.4V

IP5306H_VTHS Battery platform selection

IP5306H custom instructions:

Part Num	Description
IP5306H	Standard product
IP5306H_VTHS	Support battery full voltage selection; Support battery platform selection.

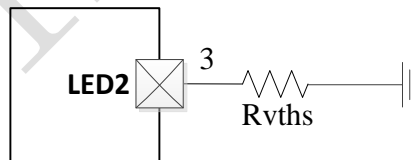

figure 10 Rvths circuit

IP5306H_VTHS support battery platform selection.(support 4 LED mode)

This model does not have Key_mode selection. Default state:

Short press: turn on

Double short press in 1s: turn off

Long press:turn on or turn off the lighting

LED2 (pin 3) connects different resistors (R_{vths}) to GND to select different battery platform. VTHS multiplexes with LED2 display output. The circuit as figure 10, The relationship between the state of the power indicator and the battery voltage is shown in the following table.The OCV in the table is not the actual voltage of the battery, It's calculated after the battery resistance compensation voltage. The calculation formula is as follows:

Charger, Voltage of the turn LED(OCV)= Actual battery voltage(IP5306H Voltage to ground on BAT (PIN 6)) - IBAT(IP5306H The current of the battery)*RSET (IP5306H Charging compensation resistor) ;

Discharger, Voltage of the turn LED(OCV)= Actual battery voltage(IP5306H Voltage to ground on BAT (PIN 6)) + IBAT(IP5306H The current of the battery)*RSET (IP5306H Charging compensation resistor) ;

4 LED mode charge and discharge OCV threshold

RVTHS		State	VSET=4.2V OCV threshold	VSET=4.3V/4.35V/4.4V OCV threshold
Threshold 1	20K 1%	4LED to 3LED	4.02V	4.02V
		3LED to 2LED	3.84V	3.84V
		2LED to 1LED	3.66V	3.78V
Threshold 2	43K 1%	4LED to 3LED	3.96V	3.96V
		3LED to 2LED	3.78V	3.84V
		2LED to 1LED	3.60V	3.66V
Threshold 3	75K 1%	4LED to 3LED	3.90V	3.96V
		3LED to 2LED	3.72V	3.78V
		2LED to 1LED	3.54V	3.60V
Threshold 4	100K 1%	4LED to 3LED	3.96V	4.08V
		3LED to 2LED	3.78V	3.84V
		2LED to 1LED	3.66V	3.72V
Threshold 5	NC	4LED to 3LED	4.02V	4.02V
		3LED to 2LED	3.84V	3.84V
		2LED to 1LED	3.66V	3.78V

12 Typical Application Schematic

IP5306H only needs capacitors, resistors, and inductors to realize a full featured power bank solution.

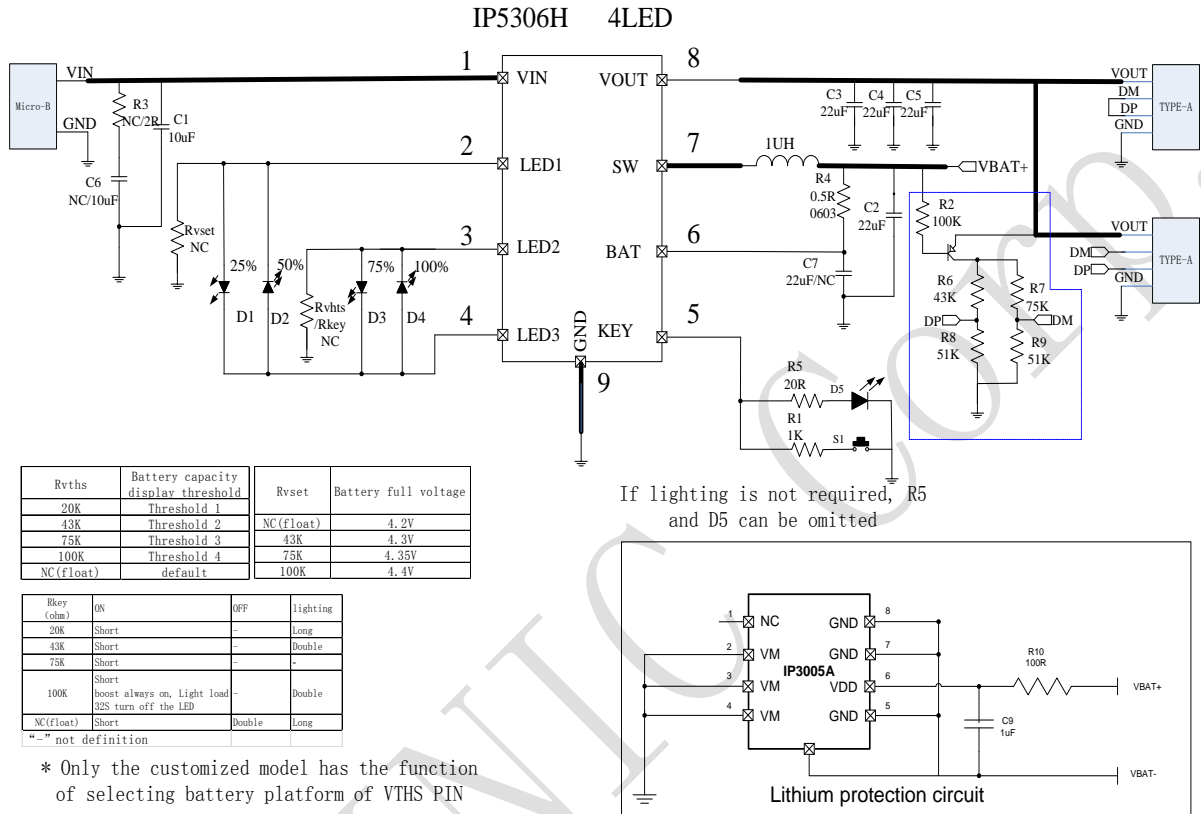

figure 11 4 LEDs SOC indicator typical application schematic

Inductor recommends:

SPM70701R0

DARFON PIN	Inductance (uH)	Tolerance	DC Resistance (mΩ)		Heat Rating	Saturation	Measuring Condition
			Typ.	Max.	Current DC Amp.	Current DC Amps.	
SPM70701R0	1.0	±20%	8.5	8	Idc(A)Max. 12	Isat(A)Max. 15	

Battery protection recommends:

INJOINIC	Pack age	Overcharge Detection Voltage [VCU] (V)	Overdischarge Detection Voltage [VDL] (V)	Overcurrent Detection Current [IOV] (A)
IP3005A	ESOP8	4.28V	2.5V	7A

13 Package information

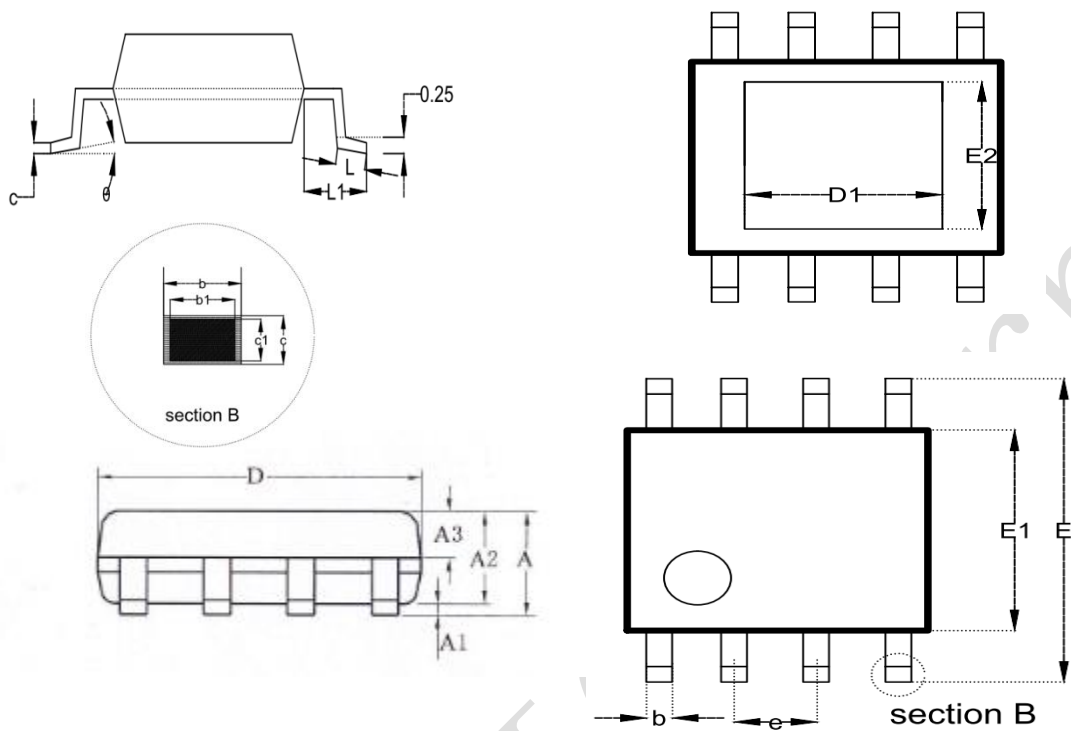

SYMBOL	MILLIMETER		
	MIN	NOM	MAX
A	--	--	1.65
A1	0.05	--	0.15
A2	1.30	1.40	1.50
A3	0.60	0.65	0.70
b	0.39	--	0.48
b1	0.38	0.41	0.43
c	0.21	--	0.25
c1	0.19	0.20	0.21
D	4.70	4.90	5.10
E	5.80	6.00	6.20
E1	3.70	3.90	4.10
e	1.27BSC		
L	0.50	0.60	0.80
L1	1.05BSC		
θ	0	--	8°
D1	--	3.10	--
E2	--	2.21	--

IMPORTANT NOTICE

INJOINIC TECHNOLOGY and its subsidiaries reserve the right to make corrections, enhancements, improvements and other changes to its semiconductor products and services. Buyers should obtain the latest relevant information before placing orders and should verify that such information is current and complete. All semiconductor products (also referred to herein as “components”) are sold subject to INJOINIC TECHNOLOGY's terms and conditions of sale supplied at the time of order acknowledgment.

INJOINIC TECHNOLOGY assumes no liability for applications assistance or the design of Buyers' products. Buyers are responsible for their products and applications using INJOINIC TECHNOLOGY's components. To minimize the risks associated with Buyers' products and applications, Buyers should provide adequate design and operating safeguards.

Buyer acknowledges and agrees that it is solely responsible for compliance with all legal, regulatory and safety-related requirements concerning its products, and any use of INJOINIC TECHNOLOGY's components in its applications, notwithstanding any applications-related information or support that may be provided by INJOINIC TECHNOLOGY. Buyer represents and agrees that it has all the necessary expertise to create and implement safeguards which anticipate dangerous consequences of failures, monitor failures and their consequences, lessen the likelihood of failures that might cause harm and take appropriate remedial actions. Buyer will fully indemnify INJOINIC TECHNOLOGY and its representatives against any damages arising out of the use of any INJOINIC TECHNOLOGY's components in safety-critical applications.

Reproduction of significant portions of INJOINIC TECHNOLOGY's information in INJOINIC TECHNOLOGY's data books or data sheets is permissible only if reproduction is without alteration and is accompanied by all associated warranties, conditions, limitations, and notices. INJOINIC TECHNOLOGY is not responsible or liable for such altered documentation. Information of third parties may be subject to additional restrictions.

INJOINIC TECHNOLOGY will update this document from time to time. The actual parameters of the product may vary due to different models or other items. This document voids all express and any implied warranties.

Resale of INJOINIC TECHNOLOGY's components or services with statements different from or beyond the parameters stated by INJOINIC TECHNOLOGY for that component or service voids all express and any implied warranties for the associated INJOINIC TECHNOLOGY's component or service and is an unfair and deceptive business practice. INJOINIC TECHNOLOGY is not responsible or liable for any such statements.