

A Power Bank SOC With Integrated H-bridge Power MOSFET Supporting Bi-directional Fast Charging Protocol Such As SCP, PD3.0, UFCS, Supporting 2~5 Series Batteries and Supporting Maximum Power 45W

1 Feature

- **Supporting 2 USB-C Ports and 1 USB-A Port Simultaneously**
 - ◇ Both USB-C ports support PD protocol input/output
 - ◇ 1 USB-A output port
- **Fast Charging**
 - ◇ Every port supports fast charging
 - ◇ Support QC2.0/QC3.0 output
 - ◇ Support FCP input/output
 - ◇ Support AFC input/output
 - ◇ Support SCP output
 - ◇ Support DRP try.SRC, PD3.0 input/output
 - ◇ Support UFCS
 - ◇ Support BC1.2, Apple
- **Integrated USB PD2.0/PD3.0 Protocol**
 - ◇ Support PD2.0 input/output protocol
 - ◇ Support PD3.0 input/output and PPS output protocol
 - ◇ Support 5V/9V/12V/15V/20V input
 - ◇ Support 5V/9V/12V/15V/20V output
 - ◇ Support adjustable voltage in 20mV/step in PPS Mode
 - ◇ Support adjustable voltage in 10mV/step in UFCS Mode
 - ◇ Integrate hardware Bi-phase mark codec (BMC) protocol
 - ◇ Integrated identification and support for E-MARK cables
 - ◇ Integrate Physical Layer protocol
 - ◇ Integrate hardware CRC
 - ◇ Support Hard Reset
- **Power Control**
 - ◇ Integrated bi-directional Buck-Boost NMOS
 - ◇ Integrated Charge-Pump to control external NMOS
- **Charge**
 - ◇ Adaptive charging current adjustment
 - ◇ Support 4.15V/4.20V/4.30V/4.35V/4.40V/3.65V (Lithium Iron Phosphate Battery) battery
 - ◇ Maximum output power 45W
 - ◇ Support charging Lithium Iron Phosphate Battery (3.65V)
 - ◇ Support 2/3/4/5 batteries in series

- **Boost**
 - ◇ Up to 94%@20V/2.25A efficiency with synchronous switching
 - ◇ Support line compensation
- **Battery Level Display**
 - ◇ Integrated 14-bit ADC and coulombmeter, more uniform power display
 - ◇ Support 4/2/1 LEDs to indicate battery level
 - ◇ Support 188 nixie tube
 - ◇ Support configuring initial battery capacity by external pin
- **Other Functions**
 - ◇ Automatic detection of mobile phone plugging and unplugging
 - ◇ Fast charging status indication
 - ◇ Battery temperature detection
 - ◇ Enter standby mode automatically in light load
 - ◇ Integrated lighting driver
- **Multiple Protections, High Reliability**
 - ◇ Input overvoltage and undervoltage protection
 - ◇ Output overcurrent, overvoltage, short circuit protection
 - ◇ Battery overcharge, overdischarge, overcurrent protection
 - ◇ Overtemperature protection
 - ◇ NTC protection for charging and discharging battery
 - ◇ ESD 4kV, input (including CC/DP/DM PINS) withstand voltage 30V
- **Low BOM Cost**
 - ◇ Integrated switch power MOSFET driver
 - ◇ Single inductor for charging and discharging
- **Package Size: 7mm × 7mm 0.4Pitch QFN60**

2 Application Product

- Power bank, Portable Energy Storage Power Supply
- Portable devices such as mobile phones and tablets
- Electric tool

3 Description

IP5383 is a power management SOC that integrates QC2.0/QC3.0/SCP/UFCS output fast charging protocol, AFC/FCP input and output fast charging protocol, TYPE-C PD2.0/PD3.0 input and output fast charging protocol and PPS output protocol, BC1.2/iPhone protocol, synchronous bi-directional buck-boost converter, lithium battery charging management and battery power indicator, providing a complete power solution for fast charging mobile power supplies. It can support one USB-A port and two USB-C ports at the same time and fast charging when any port is connected alone. When two or more output ports are used at the same time, every port's output voltage is 5V.

Due to the high integration of IP5383, only a few peripheral components are needed in the application. IP5383 integrated H-bridge power MOSFET, only one inductor is needed to realize the bidirectional buckboost function, which effectively reduces the size of the overall solution and reduces the BOM cost.

IP5383 supports 2/3/4/5 series batteries and the synchronous switch buck-boost system can provide a maximum output capacity of 45W. When there is no load, it automatically enters the dormant state.

IP5383 synchronous switch charging system provides up to 8.0A charging current. The built-in IC temperature, battery temperature and input voltage control loop intelligently adjust the charging current.

IP5383 built-in 14-bit ADC can accurately measure battery voltage and current. Built-in power calculation method can accurately obtain battery power information. The battery power curve can be customized to accurately display the battery power.

IP5383 supports 4/2/1 LED power display, supports 188 and other nixie tube power display; supports battery temperature detection.

Dictionary

1 Feature.....	1
2 Application Product.....	1
3 Description.....	2
4 Reversion History.....	5
5 Typical Application.....	6
6 IP Series Products List.....	7
6.1 Power Bank IC.....	7
6.2 IP5383 Common Custom Product Description.....	8
7 Pin Description.....	8
7.1 IP5383 Pin Description	8
8 Internal Block Diagram of the Chip.....	11
9 Limit Parameters	11
10 Recommended Operating Conditions	12
11 Electrical Characteristics.....	12
12 Description of Function	15
12.1 Lock State and Activation	15
12.2 Charging.....	15
12.3 Boost.....	16
12.3.1 USB-C	17
12.3.2 USB-C PD.....	19
12.3.3 Fast Charging Protocol.....	19
12.4 Charging and Discharging Path Management	20
12.4.1 Standby.....	20
12.4.2 Discharging	21
12.4.3 Charging.....	21
12.4.4 Charge while discharging.....	21
12.5 Automatic Detection for Mobile Phone	22
12.5.1 Automatic detection for mobile phone insertion	22
12.5.2 Automatic detection for fully charged mobile phone	22
12.6 Key Function	22

12.7 Fast Charging Status Indicator.....	22
12.8 Coulombmeter and Battery Level Display.....	23
12.8.1 Coulombmeter.....	23
12.8.2 LED Power Display Mode.....	23
12.8.3 188 Nixie Tube Display Mode.....	25
12.9 Setting the System Input/Output Maximum Power	27
12.10 Setting the series of Batteries in Series.....	28
12.11 VSET (Battery Type Setting).....	28
12.12 Intelligent Temperature Selection.....	29
12.13 NTC	29
13 Layout considerations	33
13.1 VIO and BAT Terminal Sampling Lines.....	33
13.2 The VIO and BAT capacitors need to be close to the sampling resistor, and the GND of the capacitor needs to be close to the PGND of the H-bridge	34
13.3 VCCIO capacitors and VCC5V capacitors need to be placed near the chip pins	34
13.4 The Wiring from VIO to MOSFET of output USB-A1, USB-C1 and USB-C2	35
13.5 VBAT, VIO, and CSP near the IC pins require the addition of a 0.1uF capacitor	35
14 Application Schematic	36
14.1 Application Schematic Diagram of LED Lamp Scheme	36
14.2 Digital Tube Solution Application Schematic Diagram	37
15 Package.....	39
15.1 Package of the Chip	39
15.2 Marking Description	41
16 Important Notice	42

4 Reversion History

NOTE: Page numbers for previous revisions may differ from page numbers in the current version.

First version released V1.00 (Mar 2024)	Page
• First version released.....	1
Update version V1.00 to V1.10 (Apr 2024)	Page
• Modify and update related instructions.....	6/12/13/29/33/34
Update version V1.10 to V1.20 (Jul 2024)	Page
• Add VIO&BAT&CSP 0.1uF filtering capacitors to the application schematic.....	6/35/36/37
• Update the BOM table and LAYOUT Notes.....	34/35/38

5 Typical Application

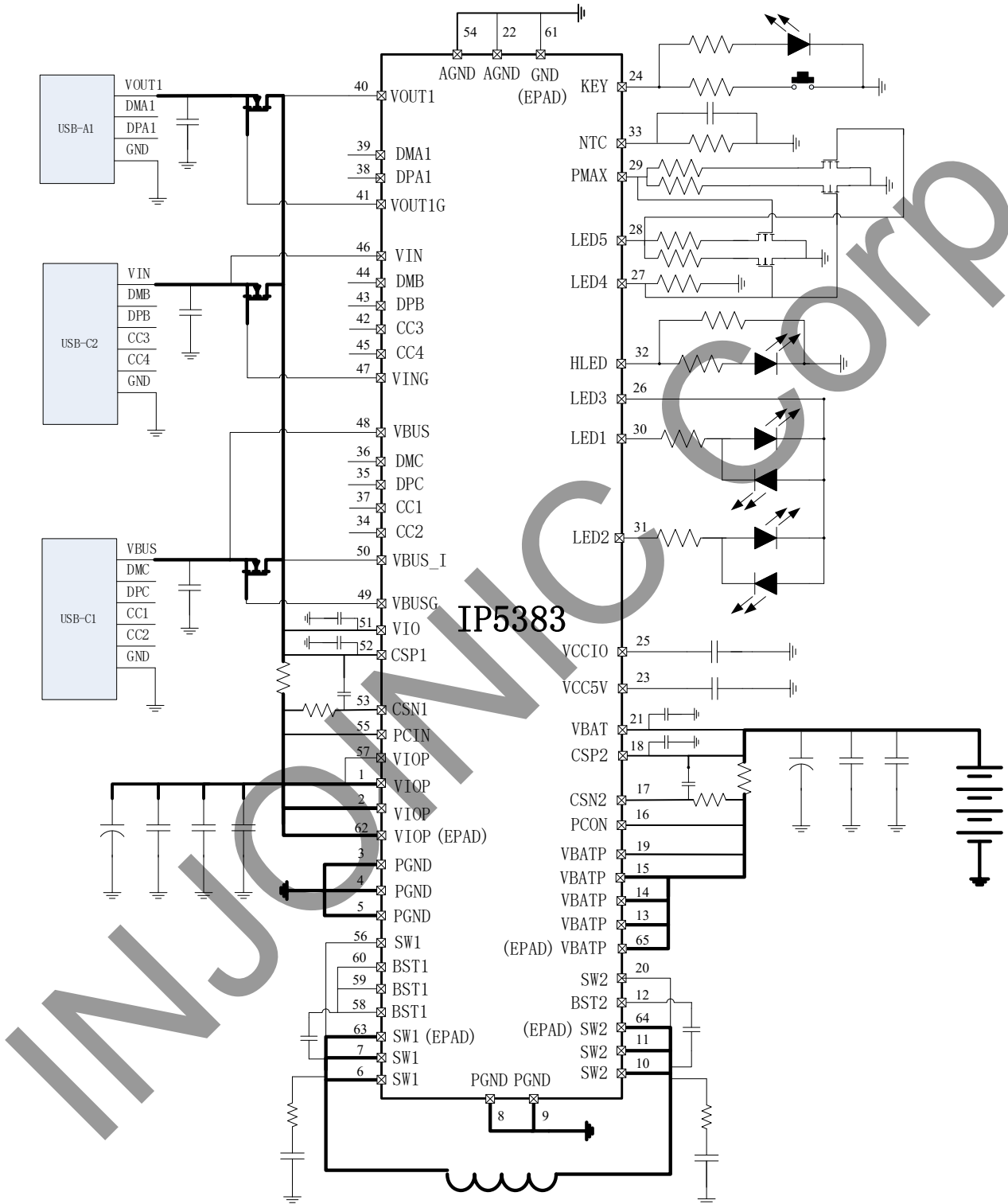

Figure 1 IP5383 Simplified Application Schematic

6 IP Series Products List

6.1 Power Bank IC

IC Part No.	boost/charge power		Main features									Package	
	boost	charge	LED number	I2C	D C P	U S B C	QC certificate	PD 3.0 /PP S	Super Charge	U F C S	Package	Com patibility	
IP5303T	5V/1A	5V/1A	1,2	-	-	-	-	-	-	-	ESOP8	PIN2PIN	
IP5305T	5V/1A	5V/1A	1,2,3,4	√	-	-	-	-	-	-	ESOP8		
IP5306	5V/2.4A	5V/2A	1,2,3,4	√	-	-	-	-	-	-	ESOP8		
IP5306H	5V/2.4A	5V/2A	1,2,3,4	√	-	-	-	-	-	-	ESOP8		
IP5406T	5V/2.4A	5V/2A	1,2,4	-	√	-	-	-	-	-	ESOP8		
IP5407	5V/2.4A	5V/2A	1,2,4	-	√	-	-	-	-	-	ESOP8		
IP5108U	5V/2A	5V/2A	3,4,5	√	-	-	-	-	-	-	ESOP16	PIN2PIN	
IP5109U	5V/2.1A	5V/2A	3,4,5	√	√	-	-	-	-	-	QFN24		
IP5207U	5V/1.2A	5V/1A	3,4,5	√	√	-	-	-	-	-	QFN24		
IP5209U	5V/2.4A	5V/2A	3,4,5	√	√	-	-	-	-	-	QFN24		
IP5207T	5V/1.2A	5V/1A	1,2,3,4	√	√	-	-	-	-	-	QFN24	PIN2PIN	
IP5189T	5V/2.1A	5V/2A	1,2,3,4	√	√	-	-	-	-	-	QFN24		
IP5189T H	5V/2.1A	5V/2A	1,2,3,4	√	√	-	-	-	-	-	QFN24		
IP5218	5V/1A	5V/1A	1,2,3,4	-	-	√	-	-	-	-	QFN16		
IP5219	5V/2.4A	5V/2A	1,2,3,4	√	-	√	-	-	-	-	QFN24		
IP5310	5V/3.1A	5V/2.6A	1,2,3,4	√	√	√	-	-	-	-	QFN32		
IP5506	5V/2.4A	5V/2A	Nixie Tube	-	-	-	-	-	-	-	ESOP16		
IP5508	5V/2.4A	5V/2A	Nixie Tube	-	√	-	-	-	-	-	QFN32		
IP5320	5V/3.1A	5V/2.6A	Nixie Tube	√	√	√	-	-	-	-	QFN28		
IP5330	5V/3.1A	5V/2.6A	Nixie Tube	-	√	√	-	-	-	-	QFN32		
IP5566	5V/3.1A	5V/2.6A	1,2,3,4	-	√	√	-	-	-	-	QFN40		
IP5332	20W	18W	1,2,3,4	√	√	√	√	√	-	-	QFN32		
IP5328P	20W	18W	1,2,3,4	√	√	√	√	√	-	-	QFN40		
IP5353	22.5W	18W	4	√	√	√	√	√	√	-	QFN32		
IP5355	22.5W	18W	4	√	√	√	√	√	√	-	QFN32		
IP5356	22.5W	18W	Nixie Tube	√	√	√	√	√	√	-	QFN40		
IP5358	22.5W	18W	Nixie Tube	-	√	√	√	√	√	-	QFN48		
IP5568	22.5W	18W	Nixie Tube	-	√	√	√	√	√	-	QFN64		
IP5568U	22.5W	18W	Nixie Tube	-	√	√	√	√	√	-	QFN64		
IP5383	45W	45W	Nixie Tube	√	√	√	√	√	√	√	QFN60		
IP5385	65W	65W	Nixie Tube	√	√	√	√	√	√	√	QFN48		
IP5386	45W	45W	Nixie Tube	√	√	√	√	√	√	-	QFN48		
IP5389	100W	100W	Nixie Tube	√	√	√	√	√	√	-	QFN64		
IP5389H	100W	100W	Nixie Tube	√	√	√	√	√	√	-	QFN64		

6.2 IP5383 Common Custom Product Description

Part No.	Function description
IP5383_LACC_BZ	Support ACC interface, support 2-5 batteries, maximum power 45W, support 4 LEDs
IP5383_S1ACC_BZ	Support ACC interface, support 2-5 batteries, maximum power 45W, support S1 nixie tube

7 Pin Description

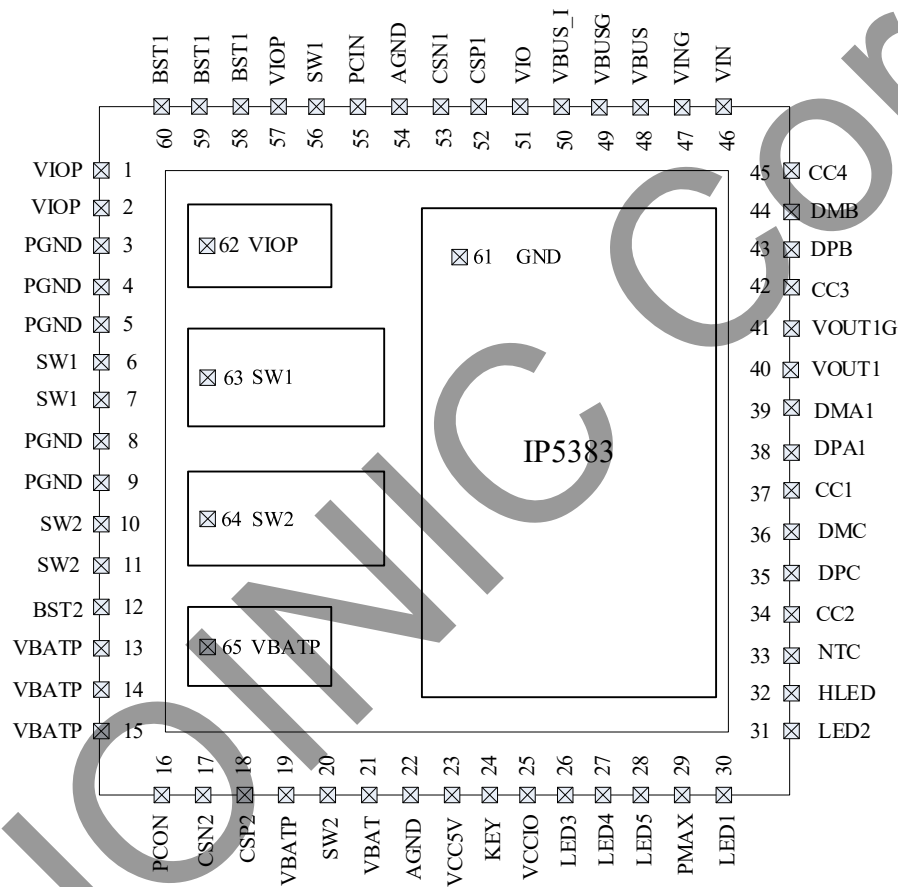

Figure 2 IP5383 Pin Diagram

7.1 IP5383 Pin Description

Pin No.	Pin Name	PIN Description
1	VIOP	Power input node of charging mode converter, power output node of boost mode converter
2	VIOP	Power input node of charging mode converter, power output node of boost mode converter
3	PGND	Power ground. Need to be in good contact with the system ground
4	PGND	Power ground. Need to be in good contact with the system ground

5	PGND	Power ground. Need to be in good contact with the system ground
6	SW1	Power switch pin, connected to the switch node of the inductor
7	SW1	Power switch pin, connected to the switch node of the inductor
8	PGND	Power ground. Need to be in good contact with the system ground
9	PGND	Power ground. Need to be in good contact with the system ground
10	SW2	Power switch pin, connected to another switch node of the inductor
11	SW2	Power switch pin, connected to another switch node of the inductor
12	BST2	Battery terminal bootstrap voltage pin of H-bridge power tube
13	VBATP	Power output node of charging mode converter, power input node of boost mode converter
14	VBATP	Power output node of charging mode converter, power input node of boost mode converter
15	VBATP	Power output node of charging mode converter, power input node of boost mode converter
16	PCON	Battery peak current sampling pin
17	CSN2	Current sampling negative terminal of battery terminal
18	CSP2	Current sampling positive terminal of battery terminal
19	VBATP	Power output node of charging mode converter, power input node of boost mode converter
20	SW2	Power switch pin, connected to another switch node of the inductor
21	VBAT	Battery terminal pin
22	AGND	Analog ground
23	VCC5V	System 5V power supply, to supply power to the internal analog circuit of the IC
24	KEY	Key and light pin
25	VCCIO	System 3.3V power supply, to supply power to the internal digital circuit of the IC
26	LED3	Used to drive power indicator
27	LED4	NTC gear position selection and reused as GPIO (General-purpose input/output)
28	LED5	Used as battery capacity selection and battery type selection
29	PMAX	Maximum input and output power selection and intelligent power gear position selection
30	LED1	Used to drive power indicator
31	LED2	Used to drive power indicator
32	HLED	Fast charge mode indicator, reused as selection of battery series connections
33	NTC	Used for NTC resistance detection
34	CC2	Used for USB-C1 port detection and fast charging communication
35	DPC	Used for USB-C1 port fast charging intelligent recognition
36	DMC	Used for USB-C1 port fast charging intelligent recognition
37	CC1	Used for USB-C1 port detection and fast charging communication
38	DPA1	Used for USB-A1 port fast charging intelligent recognition
39	DMA1	Used for USB-A1 port fast charging intelligent recognition

40	VOUT1	USB-A1 port power output from this pin
41	VOUT1G	Used to control NMOS in USB-A1 port output path
42	CC3	Used for USB-C2 port detection and fast charging communication
43	DPB	Used for USB-C2 port fast charging intelligent recognition
44	DMB	Used for USB-C2 port fast charging intelligent recognition
45	CC4	Used for USB-C2 port detection and fast charging communication
46	VIN	Input charging power pin USB-C2 port
47	VING	Used to control input path NMOS of USB-C2 port
48	VBUS	VBUS input/output power supply pin of USB-C1 port
49	VBUSG	Used to control input/output path NMOS of USB-C1 port
50	VBUS_I	Used to detect current of output port path
51	VIO	Mobile power input/output pin
52	CSP1	Current sampling positive terminal of input/output terminals
53	CSN1	Current sampling negative terminal of input/output terminals
54	AGND	Analog ground
55	PCIN	Mobile power input/output peak current sampling pin
56	SW1	Power switch pin, connected to the switch node of the inductor
57	VIOP	Power input node of charging mode converter, power output node of boost mode converter
58	BST1	Input/output terminal bootstrap voltage pin of H-bridge power MOSFET
59	BST1	Input/output terminal bootstrap voltage pin of H-bridge power MOSFET
60	BST1	Input/output terminal bootstrap voltage pin of H-bridge power MOSFET
61	GND(EPAD)	The system and heat dissipation ground. Must be in good contact with GND
62	VIOP(EPAD)	Pin connected to VIOP at the bottom of the chip
63	SW1(EPAD)	Pin connected to SW1 at the bottom of the chip
64	SW2(EPAD)	Pin connected to SW2 at the bottom of the chip
65	VBATP(EPAD)	Pin connected to VBATP at the bottom of the chip

8 Internal Block Diagram of the Chip

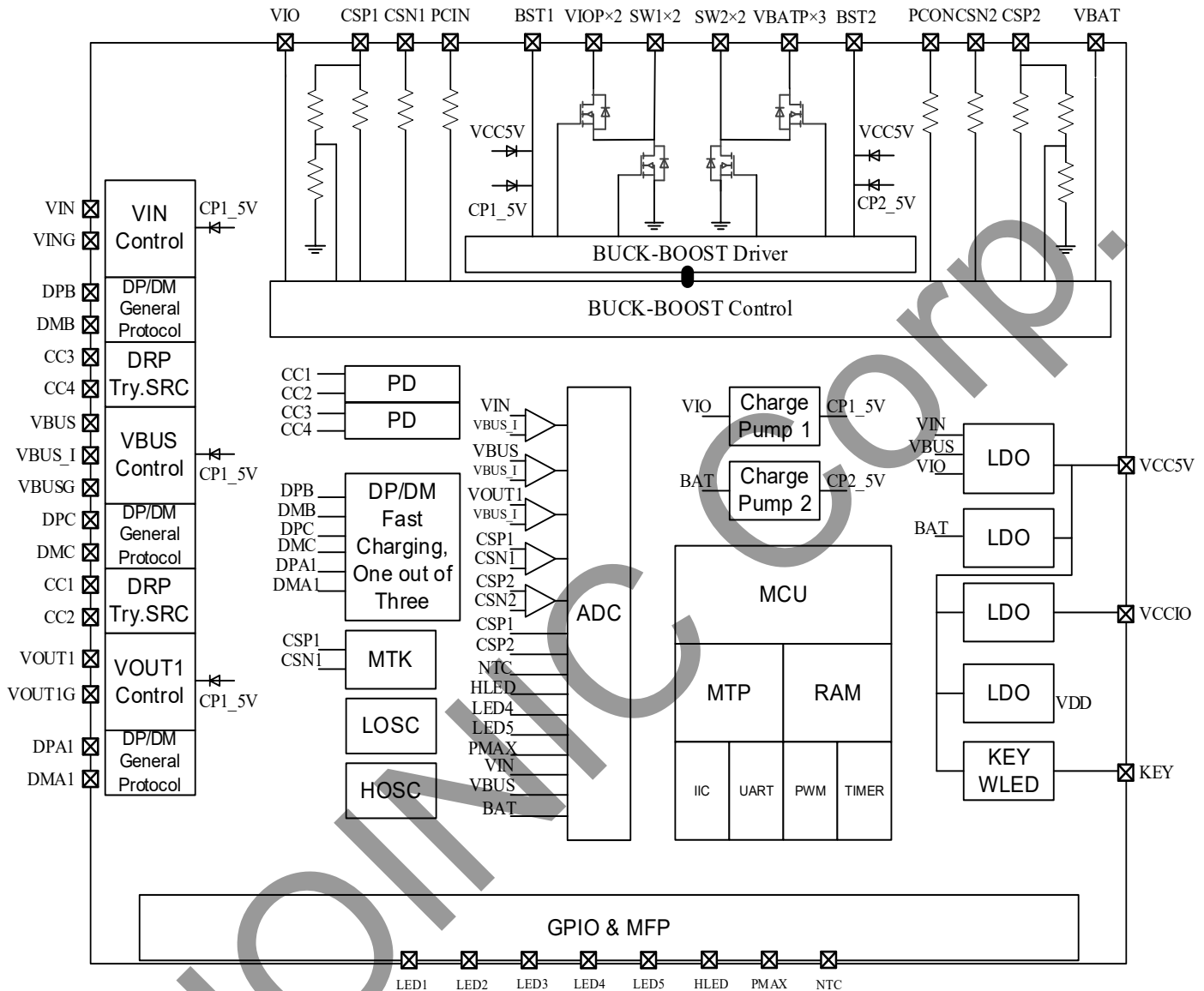

Figure 3 Internal Block Diagram of the Chip

9 Limit Parameters

Parameters	Symbol	Value	Unit
Input Voltage Range	VBAT/VIN/VBUS	-0.3 ~ 30	V
Protocol Port Voltage Range	DP/DM/CC	-0.3 ~ 30	V
Digital GPIO voltage range	LED/FCAP	-0.3 ~ 8	V
Junction Temperature Range	T _J	-40 ~ 125	°C
Storage Temperature Range	T _{stg}	-60 ~ 150	°C
Thermal Resistance (Junction to Ambient)	θ _{JA}	26	°C /W
Human Body Model (HBM)	ESD	4	KV

*Stresses higher than the values listed in the Absolute Maximum Ratings section may cause permanent damage to the device. Excessive exposure under any absolute maximum rating conditions may affect the reliability and service life of the device.

10 Recommended Operating Conditions

Parameters	Symbol	Min	Typ	Max	Unit
Battery Voltage	V _{BAT}	5.6		24	V
Input Voltage	V _{IN} /V _{BUS}	4.5		24	V
Working Temperature	T _A	-40		85	°C

*Beyond these operating conditions, device operating characteristics cannot be guaranteed.

11 Electrical Characteristics

Unless otherwise specified, T_A=25°C, L=4.7μH

Parameters	Symbol	Test Conditions	Min	Typ	Max	Unit	
Charging System							
Input voltage	V _{IN} /V _{BUS}		4.5	5/9/12/15/20	25	V	
Input overvoltage	V _{IN}			13	14	V	
	V _{BUS}			22	24	V	
Charging constant voltage	V _{TRGT}	The number of batteries is N, R _{VSET} = 27kΩ	N*4.16	N*4.20	N*4.24	V	
		The number of batteries is N, R _{VSET} = 18kΩ	N*4.26	N*4.30	N*4.34	V	
		The number of batteries is N, R _{VSET} = 13kΩ	N*4.31	N*4.35	N*4.39	V	
		The number of batteries is N, R _{VSET} = 9.1kΩ	N*4.36	N*4.40	N*4.44	V	
		The number of batteries is N, R _{VSET} = 6.2kΩ	N*4.11	N*4.15	N*4.19	V	
		The number of batteries is N, R _{VSET} = 3.6kΩ	N*3.61	N*3.65	N*3.69	V	
Charging Current	I _{CHRG}	V _{IN} =5V, input current	1.8	2.0	2.2	A	
		V _{IN} =9V, input current	1.8	2.0	2.2	A	
		V _{IN} =12V, input current	1.3	1.5	1.7	A	
		V _{BUS} =5V, input current	2.7	3.0	3.3	A	
		V _{BUS} =9V, PD, input current	P _{MAX} =20W	2	2.22	2.44	A
			P _{MAX} >=30W	2.7	3.0	3.3	A
		V _{BUS} =9V, not PD, input current	P _{MAX} >=20W	1.8	2.0	2.2	A
		V _{BUS} =12V, PD, input current	P _{MAX} =20W	1.5	1.67	1.85	A
			P _{MAX} =30W	2.2	2.5	2.8	
			P _{MAX} =35W	2.6	2.92	3.2	
P _{MAX} =45W	2.7		3.0	3.3			
V _{BUS} =12V, not PD, input current	P _{MAX} >=20W	1.3	1.5	1.7	A		

		VBUS=15V, input current	P _{MAX} =20W	1.1	1.33	1.5	A	
			P _{MAX} =30W	1.8	2.0	2.2		
			P _{MAX} =35W	2.1	2.33	2.55		
			P _{MAX} =45W	2.7	3.0	3.3		
			VBUS=20V, input current	P _{MAX} =20W	0.8	1	1.2	A
				P _{MAX} =30W	1.3	1.5	1.7	
				P _{MAX} =35W	1.55	1.75	1.95	
				P _{MAX} =45W	2.0	2.25	2.5	
Trickle Charging Current	I _{TRKL}	VIN=5V, VBAT<2.5V		40	100	mA		
		VIN=5V, 2.5V<=VBAT<N*3.0V	200	0.05*FCAP	1000	mA		
Trickle Cut-off Voltage	V _{TRKL}	The number of batteries is N, V _{TRGT} is not 3.65V	N*2.9	N*3.0	N*3.1	V		
	V _{TRKL}	The number of batteries is N, V _{TRGT} is 3.65V	N*2.7	N*2.75	N*2.85	V		
Charging Stop Current	I _{STOP}		200	0.05*FCAP		mA		
Recharging Threshold Voltage	V _{RCH}	The number of batteries is N		V _{TRGT} – N*0.1		V		
Charging Cut-off Time	T _{END}		45	48	51	Hour		
Boost System								
Battery Operation Voltage	V _{BAT}	The number of batteries is N	N*2.75		N*4.5	V		
DC Output Voltage	QC2.0 V _{OUT}	V _{OUT} =5V@1A	4.75	5.00	5.25	V		
		V _{OUT} =9V@1A	8.70	9.00	9.30	V		
		V _{OUT} =12V@1A	11.60	12.00	12.40	V		
	QC3.0 V _{OUT}	@1A	3.6		12	V		
	QC3.0 Step			200		mV		
	PPS Step				20	mV		
UFCS Step				10	mV			
Output Voltage Ripple	ΔV _{OUT}	VBAT=4*3.7V, V _{OUT} =5V, Fs=400kHz, I _{out} =1A		100		mV		
		VBAT=4*3.7V, V _{OUT} =9V, Fs=400kHz, I _{out} =1A		100		mV		
		VBAT=4*3.7V, V _{OUT} =12V, Fs=400kHz, I _{out} =1A		100		mV		
		VBAT=4*3.7V, V _{OUT} =15V, Fs=400kHz, I _{out} =1A		150		mV		

		VBAT=4*3.7V, VOUT=20V, Fs=400kHz, Iout=1A		150		mV
Maximum Output Power of Discharge System	P _{max}	Under the PD protocol, different P _{MAX} resistance values correspond to different P _{max}			45	W
Boost Efficiency	η _{out}	V _{BAT} =15V, V _{OUT} =5V, I _{OUT} =3A		90		%
		V _{BAT} =15V, V _{OUT} =9V, I _{OUT} =3A		94.2		%
		V _{BAT} =15V, V _{OUT} =12V, I _{OUT} =3A		94		%
		V _{BAT} =15V, V _{OUT} =15V, I _{OUT} =3A		94		%
		V _{BAT} =15V, V _{OUT} =20V, I _{OUT} =2.25A		95.3		%
Boost System Shutdown Current	I _{shut}	VBAT=N*3.7V, multiple ports output 5V	4.3	4.6	5.0	A
		VBAT= N *3.7V, single port output 5V	3.2	3.6	4.0	A
		VBAT= N *3.7V, single port output 9V, not under PD protocol condition	2.7	3.07	3.38	A
		VBAT= N *3.7V, single port output 12V, not under PD protocol condition	2.07	2.3	2.53	A
		VBAT= N *3.7V, single port output, under PD protocol condition		PDO * 1.15		A
Output Line Compensation Voltage	V _{COMP}	V _{IO} ≤9V		70		mV/A
Shutdown Power Threshold under Light Load Condition	P _{out}	VBAT=3.7V		350		mW
Detection Time for Overcurrent Load	T _{UV_D}	The output voltage is continuously lower than 2.4V		30		ms
Detection Time for Short-circuit Load	T _{OCD}	The output voltage is continuously lower than 2.2V		40		μs
Control System						
Switch Frequency	Fs	Discharging switch frequency		400		kHz
		Charging switch frequency		400		kHz
VCCIO Output Voltage	V _{CCIO}		3.15	3.30	3.45	V
Standby Current at the Battery Terminal	I _{STB}	VBAT=14.8V, the average current after the key is turned off		100	150	μA
VCCIO Output Current	I _{LDO}		25	30	35	mA

The Driving Current for LED Lighting	I_{WLED}		10	15	20	mA
The Driving Current for LED Display	I_{L1} I_{L2} I_{L3}	Voltage decreases 10%		3	9	mA
Detection Time for Automatic Shutdown when Total Load is Light	T_{1load}	The load power is continuously less than 350mW	30	32	34	s
Detection Time for Automatic Shutdown of Output Port under Light Load	T_{2load}		14	16	18	s
Detection Time of Short Press on Key for Waking	$T_{OnDebounce}$		60		500	ms
The Time of Turning On WLED	$T_{Keylight}$		1.2	2	3	s
Temperature which Leads to Power Off	T_{OTP}	Heating	110	125	140	°C
Temperature Hysteresis after Power Off	ΔT_{OTP}			40		°C

12 Description of Function

12.1 Lock State and Activation

When the IP5383 is connected to the battery for the first time, no matter what the battery voltage is, the chip is in a lock state, and the lowest digit of the battery indicator will flash 4 times, or the nixie tube 0% will flash 4 times to indicate. When not in the charging state, if the battery voltage is too low, the shutdown will be triggered, and IP5383 will go into lock state at this time.

In the low battery state, in order to reduce static power consumption, IP5383 can't detect the insertion of the load and it can't be activated by pressing the key. At this time, pressing the key can't activate the buck-boost output, but the lowest battery indicator will flash 4 times to prompt.

In the lock state, the chip can be activated only after entering the charging state.

12.2 Charging

IP5383 integrates the trickle current, constant current and constant voltage lithium battery charging management system with synchronous switch structure, and supports automatic matching of different charging voltage specifications:

When the battery voltage is less than V_{TRKL} , it will apply trickle charging;

When the battery voltage is greater than V_{TRKL} , it will apply constant current charging, and the

maximum charging current of the battery terminal is 8.0A;

When the battery voltage is close to the setting value, it will apply constant voltage charging.

When the battery terminal charging current is less than the stop charging current I_{STOP} and the battery voltage is close to the constant voltage, the charging is stopped. After the charging is completed, if the battery voltage is lower than $(V_{TRGT-N} \times 0.1)$ V, it will restart the battery charging.

IP5383 has switch charging technology with a switching frequency of 400kHz. When charging with ordinary 5V input, the input power is 15W; when charging with fast charging input, the maximum input power is 45W. The charging efficiency can reach 96%, which can shorten the charging time by 3/4.

IP5383 supports simultaneous charging and discharging. When charging and discharging simultaneously, both input and output are 5V.

12.3 Boost

IP5383 integrates a synchronous switching converter system that supports high-voltage output and supports a wide voltage range of 3.0V~21V. The synchronous switching buck-boost system can provide a maximum output capacity of 65W. The built-in soft-start function prevents malfunctions caused by excessive inrush current during start-up. It also has output overcurrent, short circuit, overvoltage, overtemperature and other protective functions to ensure the stable and reliable operation of the system.

The current of the discharging system can be automatically adjusted with the temperature to ensure that the IC temperature is below the set temperature.

$V_{BAT}=7.6V$, $V_{OUT}=5/9/12/15/20V$, the boost efficiency curve is as follows:

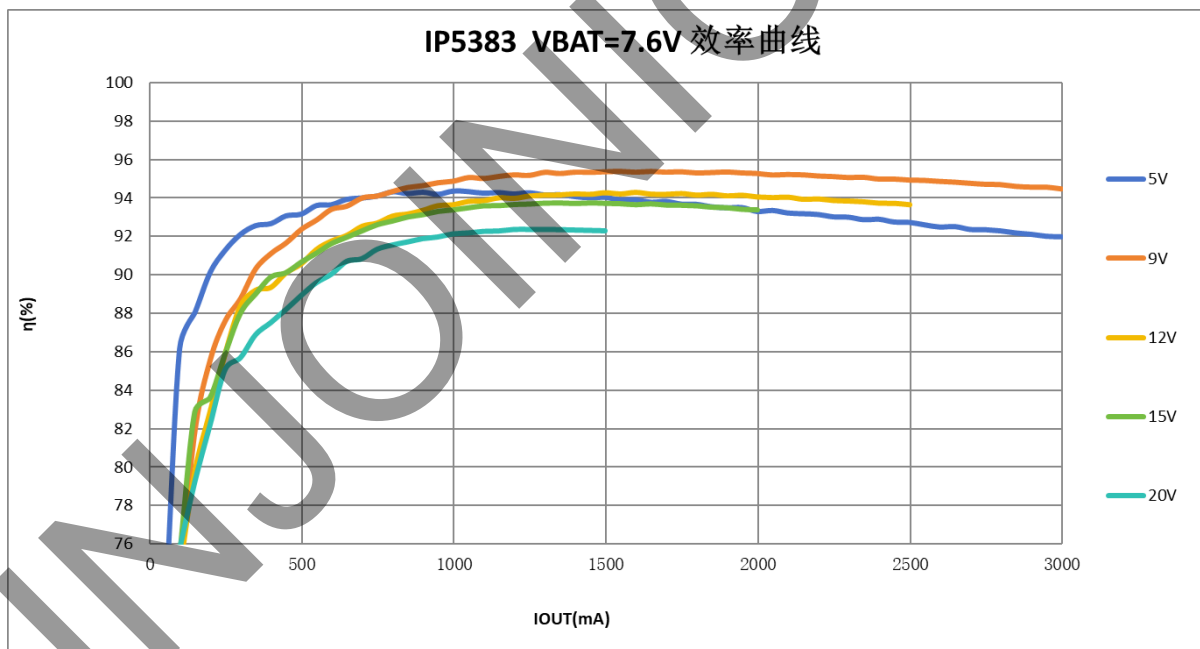

Figure 4 Boost Efficiency Curve Under The Condition Of $V_{BAT}=7.6V$

12.3.1 USB-C

IP5383 integrates USB C input and output recognition interfaces, automatically switches the built-in pull-up and pull-down resistors, and automatically recognizes charging and discharging properties of the inserted device. With Try.SRC function, when the attached device is also DRP device, IP5383 will supply power for the opposite device.

When it works as a DFP, it will output 3A current capability information through CC pin; when it works as a UFP, it can identify the output current capability of the opposite device.

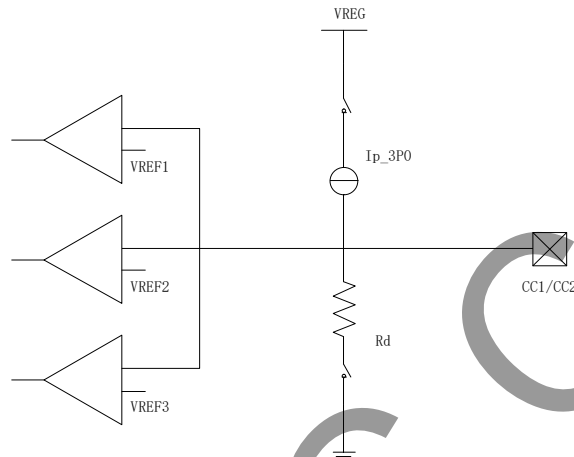

Figure 5 CC Internal Circuit

Name	Value
Ip_3P0	330 μ A
Rd	5.1k Ω

Table 1 Pull-up and Pull-down Ability

	Minimum Voltage	Maximum Voltage	Threshold
Powered cable/adaptor (vRa)	0.00V	0.75V	0.80V
vRd-Connect	0.85V	2.45V	2.60V
No connect (vOPEN)	2.75V		

Table 2 Comparator Threshold of Pull-Up Ip

Detection	Min voltage	Max voltage	Threshold
vRa	-0.25V	0.15V	0.20V
vRd-Connect	0.25V	2.04V	
vRd-USB	0.25V	0.61V	0.66V
vRd-1.5	0.70V	1.16V	1.23V
vRd-3.0	1.31V	2.04V	

Table 3 Comparator Threshold of Pull-down Ip

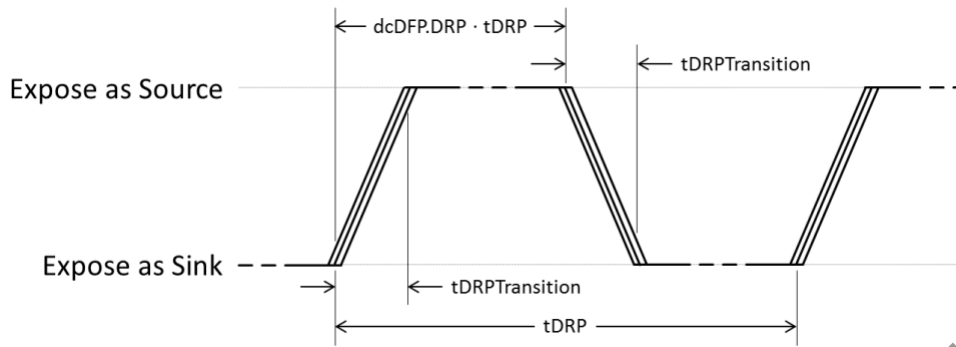

Figure 6 USB-C Detection Cycle

	Minimum	Maximum	Description
tDRP	50 ms	100 ms	The period a DRP shall complete a Source to Sink and back advertisement
dcSRC.DRP	30%	70%	The percent of time that a DRP shall advertise Source during tDRP
tDRPTransition	0 ms	1 ms	The time a DRP shall complete transitions between Source and Sink roles during role resolution
tDRPTry	75 ms	150 ms	Wait time associated with the Try.SRC state.
tDRPTryWait	400 ms	800 ms	Wait time associated with the Try.SNK state.
tTryTimeout	550 ms	1100 ms	Timeout for transition from Try.SRC to TryWait.SNK .
tVPDDetach	10 ms	20 ms	Time for a DRP to detect that the connected Charge-Through VCONN-Powered USB Device has been detached, after VBUS has been removed.

Table 4 USB-C Detection Cycle



图 7 USB-C Detection State Transition

12.3.2 USB-C PD

IP5383 integrates USB-C Power Delivery PD2.0/PD3.0/PPS (Programmable Power Supply) protocol, physical (PHY) layer for data transmitting/receiving across the CC wire and hardware biphasic mark coding (BMC) module.

IP5383 supports PD2.0/PD3.0 bidirectional input/output protocol and PPS output protocol. The maximum output power is 45W. Input voltage gears include 5V, 9V, 12V, 15V, 20V. Output voltage gears include 5V, 9V, 12V, 15V, 20V.

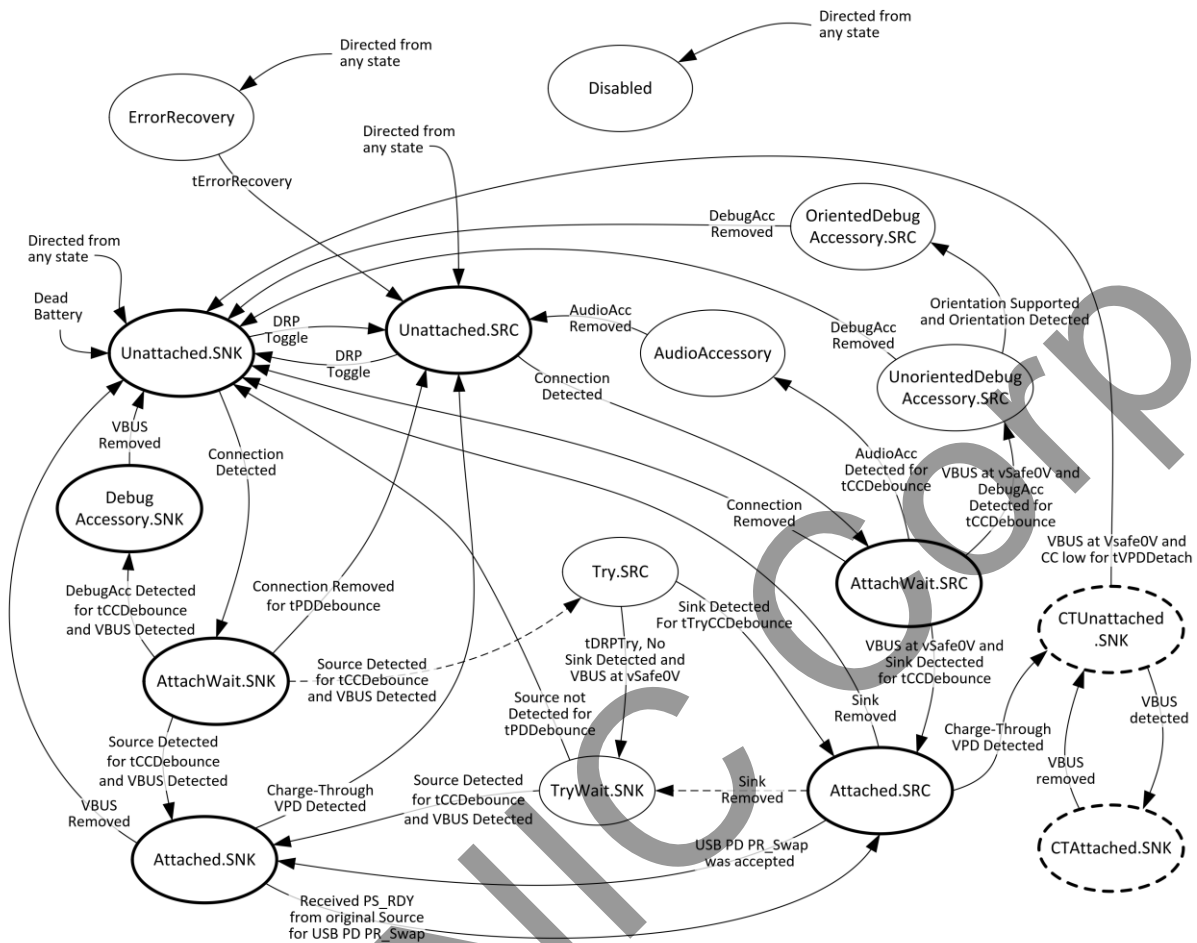
Broadcast capability is 5V/3A, 9V/3A, 12V/3A, 15V/3A, 20V/2.25A, PPS 3.3~16V/3A.

12.3.3 Fast Charging Protocol

IP5383 supports multiple fast charging protocols: QC2.0, QC3.0, FCP, AFC, SCP, VOOC, Apple, UFCS.

When the mobile power bank charges the mobile phone, it will automatically detect the fast charging sequence on the DP and DM Pins after entering the discharge mode, and intelligently identify the type of mobile phone, which support QC2.0/QC3.0/QC3+, FCP, AFC, SCP, UFCS protocol, Apple 2.4A mode, BC1.2 ordinary 1A mode.

For Apple 2.4A mode: DP=DM=2.7V.

For BC1.2 mode: DP short to DM.

In the BC1.2 mode, when the DP voltage is detected to be greater than 0.325V and less than 2V for 1.25s, the initial judgment is that there is a fast charging request. At this time, the short circuit between DP and DM will be disconnected, and DM will be pulled down to ground by a 20k Ω resistor. If it is satisfied that the DP voltage is greater than 0.325V and less than 2V, and the DM voltage is less than 0.325V for 2ms, the fast charging connection is considered successful. After that, the requested voltage can be output according to the requirements of QC2.0, QC3.0. As long as the DP voltage is less than 0.325V, the fast charge mode is forced to exit, and the output voltage immediately returns to the default 5V.

DP	DM	Result
0.6V	0V	5V
3.3V	0.6V	9V
0.6V	0.6V	12V
0.6V	3.3V	Continuous Mode
3.3V	3.3V	保持

Table 5 QC2.0, QC3.0 Rules For Requesting Output Voltage

Continuous Mode is the unique working mode of QC3.0. In this mode, the output voltage can be adjusted in a 200mV step according to the QC3.0 protocol requirements.

Protocols	USB-A1 Output	USB-C Output	USB-C Input
QC2.0	√	√	-
QC3.0	√	√	-
QC3+	-	-	-
AFC	√	√	√
FCP	√	√	√
SCP	√	√	-
VOOC	√	-	-
PD2.0	-	√	√
PD3.0	-	√	√
PPS	-	√	-
UFCS	√	√	-

Table 6 The Fast Charging Protocol Supported by Each Port of IP5383

Supported: √
 not supported: -

12.4 Charging and Discharging Path Management

12.4.1 Standby

If USB-C is connected to a power supply, charging can be started directly.

If a USB-C UFP device is inserted into USB-C or an electrical device is inserted into USB-A, the discharging function can be automatically turned on.

IP5383 will turn on when the key is pressed or there is a load on USB-A1 or USB-C, otherwise it will keep standby state.

12.4.2 Discharging

When the key is not pressed, only the path of the output port that is connected to electrical device will be opened, and the path of the output port that is not connected to electrical device will be closed.

Any port of USB-A1, USB-C1, USB-C2 can support output fast charging protocol, because of a single inductor solution, it can only support one voltage output. In other words, It only supports fast charging output when only one output port is turned on. When two or three output ports are used at the same time, the fast charging function will be automatically turned off.

According to the connection shown in the "Simplified application schematic", when any output port has entered fast charging output mode, if another output port is plugged in with an electrical device, it will first close all the output ports, turn off the high-voltage fast charge function, and then turn on the output port where the device exists. At this time, all the output ports only support Apple and BC1.2 charging. When in the multi-port output mode, if the output current of any output port is less than about 80mA (MOS Rds_ON@15mΩ), the port will be automatically closed after 16s. When it is detected that the number of electrical device is reduced from multiple to one, after about 16s, all output ports will be closed first, then the high-voltage fast charging function will be turned on, and the output port connected to the electrical device will be turned on. In this way, the device can be reactivated to request a fast charging. When only one output port is turned on, and total output power is less than about 350mW for about 32s, IP5383 will close the output port, stop discharging and enter standby state.

12.4.3 Charging

Any one of USB-C1 and USB-C2 can be plugged into a power source to charge the battery. If they are all connected to the power source, the first plugged-in power source will be used first for charging.

In the case of charging only, it will automatically recognize the fast charging mode of the power supply and automatically match the appropriate charging voltage and charging current.

12.4.4 Charge while discharging

When the charging power supply and the electrical device are plugged in at the same time, the chip will automatically enter the charging and discharging mode. In this mode, it will automatically close the internal fast charging input request. In order to charge the electrical device normally, IP5383 will increase the charging undervoltage loop to above 4.9V to ensure that the electrical device is given priority to supply power. When the VIO voltage is only 5V, the discharging path is opened to supply power to the electrical device; if the VIO voltage is greater than 5.6V, for safety reasons, the discharging path will not be opened.

During the charging and discharging process, if the charging power is unplugged, IP5383 will turn off the charging and restart discharging to supply power to the electrical device. For safety reasons, and to reactivate the mobile phone to request fast charging, the voltage will drop to 0V for a period of time during the conversion process.

During the charging and discharging process, if the electrical device is unplugged, or the electrical device is fully charged and stops drawing power, the corresponding discharging path will be automatically closed after about 16s. When the discharging paths are closed and the state returns to the charging only mode, the charging undervoltage loop will be lowered and the fast charging will be automatically reactivated, then the charging of the mobile power supply will be accelerated.

12.5 Automatic Detection for Mobile Phone

12.5.1 Automatic detection for mobile phone insertion

If an inserted phone has been automatically detected by IP5383, IP5383 will wake up from standby state immediately and turn on the boost to charge the phone. This design can save the step of turning on the key and support the mold scheme without key.

12.5.2 Automatic detection for fully charged mobile phone

IP5383 samples the output current of each port through the on-chip ADC. When the output current of a single port is less than about 80mA (MOS $R_{ds_ON}@15m\Omega$) and lasts for about 16s, the output port will be closed. When the total output power is less than about 350mW and lasts for about 32s, it is considered that the mobile phones of all output ports are fully charged or unplugged, and the buck-boost output will be automatically turned off.

12.6 Key Function

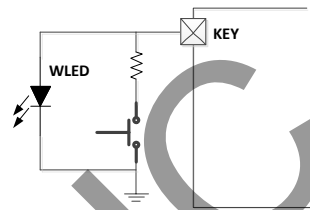

Figure 8 KEY Circuit

Key circuit is illustrated in Figure 8, which can recognize short press or long press operation.

- Pressing the key for longer than 100ms but less than 2s is a short press action. Short press will turn on the battery indicator and boost output.
- Pressing the key for longer than 2s is a long press action. Press and hold to turn the light on or off.
- There will be no response when the key is pressed for less than 30ms.
- Short press the button for two consecutive times within 1s, the boost output and power display will be turned off.
- Long press for 10s to reset the entire system.

12.7 Fast Charging Status Indicator

HLED is used to indicate the current fast charging mode. Regardless of charging or discharging, the indicator will automatically light up when entering the fast charging mode and the output is not 5V.

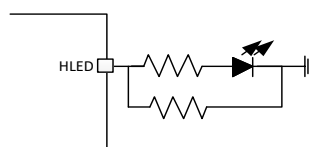

Figure 9 Fast Charging State Indication

12.8 Coulombmeter and Battery Level Display

IP5383 has a built-in coulombmeter, which can realize accurate battery power calculation.

IP5383 supports 4-LED,2-LED,1LED mode.

IP5383 supports 188 nixie tube to display power.

12.8.1 Coulombmeter

IP5383 supports externally setting the initial capacity of the battery, and uses the integral of the current and time of the battery terminal to manage the remaining capacity of the battery. When a 5 mΩ detection resistor is used between the battery current detection pins CSP2 and CSN2, the current battery capacity can be accurately displayed.

IP5383 sets the system battery capacity by determining the R24 resistance value of the FCAP pin connection, with R24 defaulting to 5kΩ.

The minimum supported capacity is 2000mAH, and the maximum supported capacity is 30000mAH, which is the capacity of a single battery.

When the voltage on the FCAP pin is less than 100mV or greater than 2700mV, the R24 resistor recognizes a short circuit or open circuit state, resulting in abnormal capacity initialization settings.

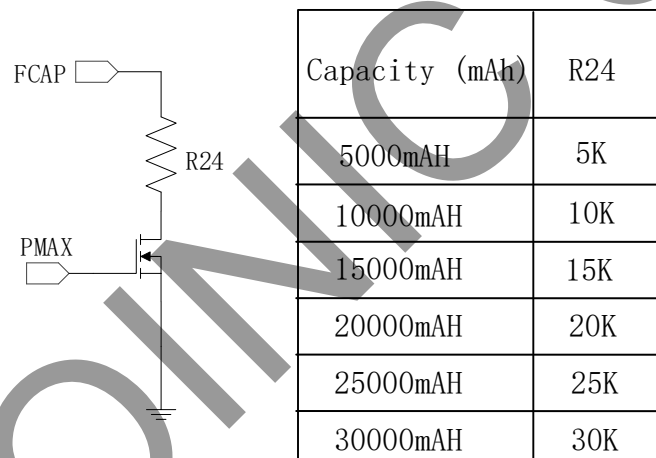

Battery capacity (mAh): $R * 1.0$

Note: The capacity here refers to the capacity of a single battery. For example, three 5000mAh batteries in series, set the capacity to 5000mAh, choose 5K for R24.

Figure 10 Battery Capacity Configuration Circuit

12.8.2 LED Power Display Mode

IP5383 4-LED,2-LED,1-LED mode to display the capacity of the battery is as follows:

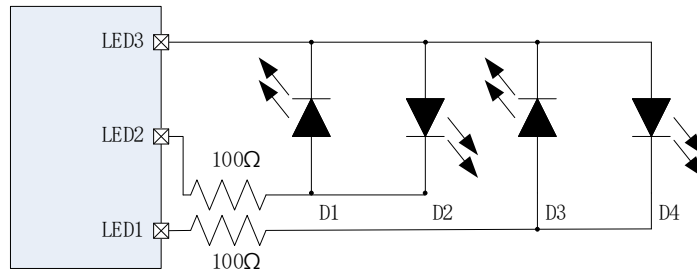

4 LED

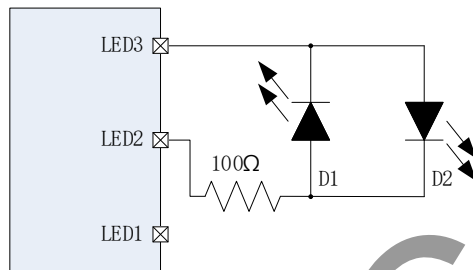

2 LED

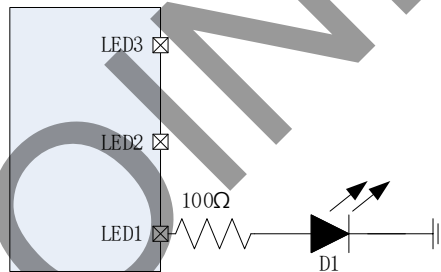

1 LED

Figure 11 4/2/1-LED Connection

4-LED display mode:

Charging:

Battery Capacity (%)	D1	D2	D3	D4
Fully charged	ON	ON	ON	ON
$75\% \leq C$	ON	ON	ON	0.5Hz Flash
$50\% \leq C < 75\%$	ON	ON	0.5Hz Flash	OFF
$25\% \leq C < 50\%$	ON	0.5Hz Flash	OFF	OFF

$C < 25\%$	0.5Hz Flash	OFF	OFF	OFF
------------	-------------	-----	-----	-----

Table 7 Charging LED Display

Discharging

Battery Capacity (%)	D1	D2	D3	D4
$C \geq 75\%$	ON	ON	ON	ON
$50\% \leq C < 75\%$	ON	ON	ON	灭
$25\% \leq C < 50\%$	ON	ON	OFF	OFF
$5\% \leq C < 25\%$	ON	OFF	OFF	OFF
$0\% < C < 5\%$	1Hz Flash	OFF	OFF	OFF
$C = 0\%$	OFF	OFF	OFF	OFF

Table 8 Discharging LED Display

2-LED display mode:

charging: The D1 flashes in a 2s cycle (1s on and 1s off), and is always on when fully charged.

discharging: The D2 is always on, and when the power is lower than 5%, it flashes at 1Hz (0.5s on and 0.5s off).

1-LED display mode:

charging: The D1 flashes in a 2s cycle (1s on and 1s off), and is always on when fully charged.

discharging: The D1 is always on, and when the power is lower than 5%, it flashes at 1Hz (0.5s on and 0.5s off).

Note: The 2 lamp and 1 lamp modes need to be customized, and the schematic diagram of the corresponding model does not need to be changed. Simply refer to the above figure to change the peripheral circuits of the LED1, LED2, and LED3 pins.

12.8.3 188 Nixie Tube Display Mode

The nixie tube supported by IP5383 is as follows:

Nixie Tube	During charging		During discharging	
	Not fully charged	Fully charged	Battery capacity <5%	Battery capacity >5%
188	0-99% ones place 0.5Hz Flash	100% always on	0-5% ones place 1Hz Flash	5%-100% always on

Table 9 Nixie Tube Display Mode

S1 type 188 nixie tube is as follows:

(未注尺寸公差 Unspecified Tolerances is: ± 0.2)

发光颜色: 白色、翠绿

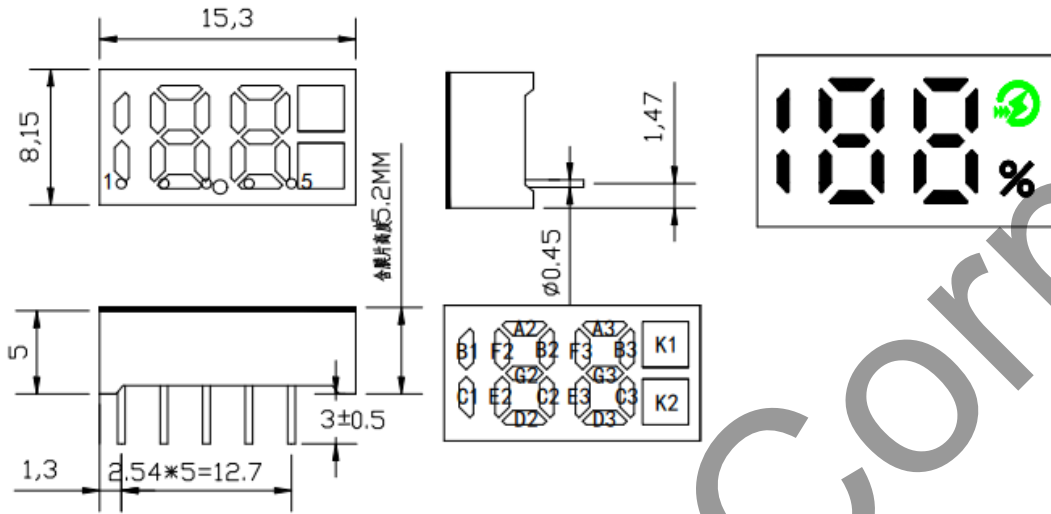

Figure 12 Nixie Tube

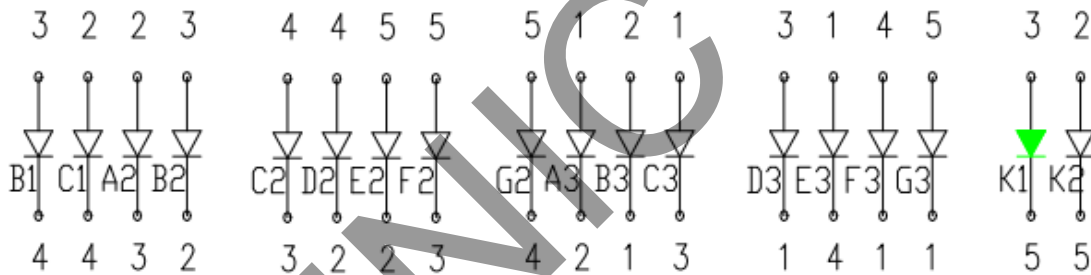
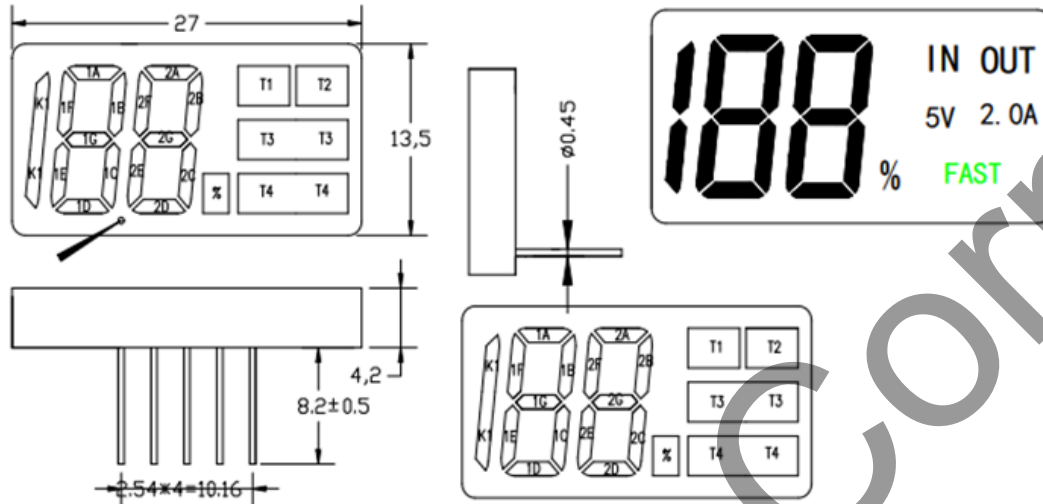

Figure 13 S1 type 188 Nixie Tube Circuit

S2 type 188 nixie tube is as follows:

3. 结构尺寸 (Mechanical Outline) :

(未注尺寸公差 Unspecified Tolerances is: ± 0.2 发光颜色: 白色、翠绿)



4. 电路图 (Circuit Diagram) :

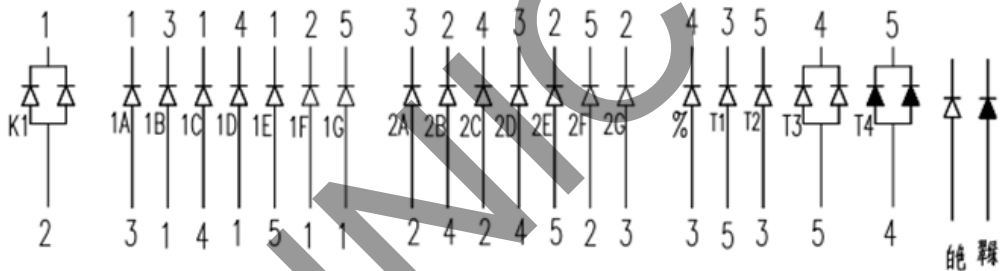

Figure 14 S2 type 188 Nixie Tube Circuit

12.9 Setting the System Input/Output Maximum Power

IP5383 sets the maximum input and output power of the system by judging the resistance value connected to the PMAX PIN.

Input and output maximum power configuration table:



R42	Maximum Input Power	Maximum Output Power
33k Ω	45W	45W
27k Ω	30W	45W
18k Ω	35W	35W
13k Ω	30W	30W
9.1k Ω	30W (maximum input voltage 15V)	30W
6.2k Ω	30W (maximum input voltage 15V)	30W (maximum output voltage 15V)
3.6k Ω	20W	30W

Figure 15 Power Configuration And Connection Method

12.10 Setting the series of Batteries in Series

IP5383 sets the series of system batteries in series by judging the resistance value of the R39 resistor connected to the HLED pin, and configures the corresponding battery parameters. IP5383 supports the selection of 2-5 series connected batteries.

Configuration table of the series of batteries in series:

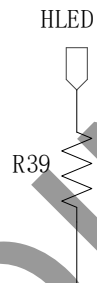

R39	Number of series connected batteries
10k Ω	5
7.5k Ω	4
5k Ω	3
2.5k Ω	2

Figure 16 Setting the series Of Batteries In Series

12.11 VSET (Battery Type Setting)

IP5383 sets the battery type by outputting 80 μ A current to the resistor connected to GND on the FCAP PIN and judging the voltage on the FCAP, thereby changing the battery display threshold, the constant voltage for charging the battery, and the protection voltage. The different resistances to GND connected to FCAP and the corresponding different battery types are shown in the following table. When the voltage of FCAP exceeds all judgment ranges, the chip will recognize the circuit as a short circuit or an abnormal open circuit. The value of resistance between FCAP pin and GND and set battery type are as follows:

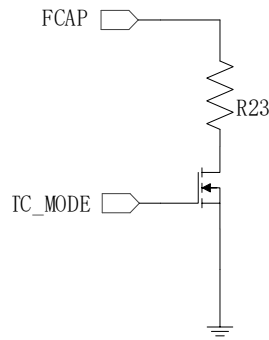

Resistance from FCAP to GND	FCAP voltage (Theoretical Voltage)	FCAP Voltage Judgment Range	Corresponding Battery Type
27kΩ	2160mV	1750mV~2550mV	4.20V
18kΩ	1440mV	1220mV~1750mV	4.30V
13kΩ	1040mV	860mV~1220mV	4.35V
9.1kΩ	728mV	600mV~860mV	4.40V
6.2kΩ	496mV	384mV~600mV	4.15V
3.6kΩ	288mV	216mV~384mV	3.65V

Table 10 Battery Type Setting

Note:

- 3.65V refers to lithium iron phosphate battery and corresponding turn-off voltage is 2.75V.
- Note that the accuracy of the external resistance should be 1% and the voltage of FCAP should be in the middle of the judgment range.

12.12 Intelligent Temperature Selection

IP5383 outputs 80μA current on the PMAX pin, connect different resistors R75 to GND to set the battery type and configure intelligent temperature selection during battery charging and discharging.

When IP5383 detects that its own temperature has reached the threshold, it will automatically adjust the charging/discharging power to maintain its own temperature below the threshold.

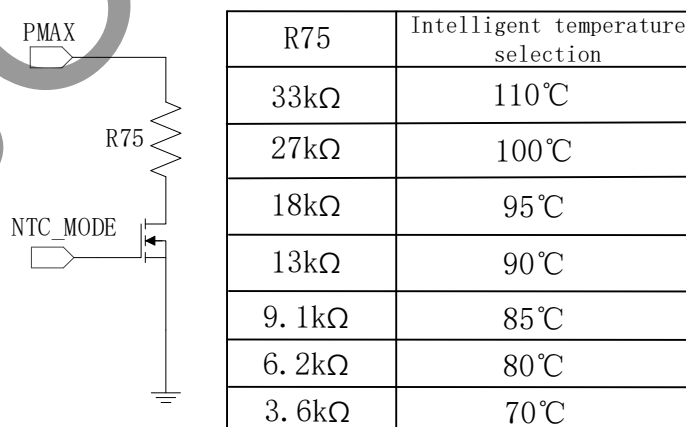

Figure 17 Intelligent temperature selection

12.13 NTC

IP5383 integrates NTC function, which can detect battery temperature. When the IP5383 is working,

a constant current source is generated at the NTC pin, and an external NTC resistor is used to generate a voltage. The IC internally detects the voltage of the NTC pin to determine the current battery temperature.

*Connect a 100nF capacitor in parallel with the NTC PIN to GND, the capacitor needs to be placed close to the chip PIN.

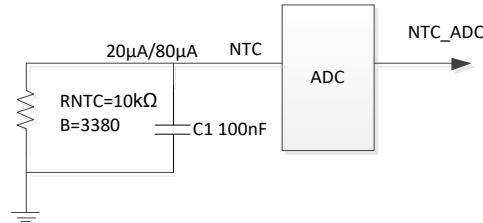

Figure 18 NTC Circuit

IP5383 discharges 80µA current on the NTC_MODE PIN. If this PIN is connected with different resistors, different voltages can be obtained. The IC will detect the NTC_MODE voltage and select different NTC functions according to the NTC_MODE voltage. When the voltage of NTC_MODE exceeds all judgment ranges, the chip will recognize the circuit as a short circuit or an abnormal open circuit.



Figure 19 NTC Gear Selection

NTC_MODE External Resistance	NTC_MODE Theoretical Voltage	NTC_MODE Voltage Judgment Range	NTC Function
27 kΩ	2160 mV	1750 mV~2550 mV	NTC sixth gear
18 kΩ	1440 mV	1220 mV~1750 mV	NTC fifth gear
13 kΩ	1040 mV	860 mV~1220 mV	NTC fourth gear
9.1 kΩ	728 mV	600 mV~860 mV	NTC third gear
6.2 kΩ	496 mV	380 mV~600 mV	NTC second gear
3.6 kΩ	288 mV	216 mV~380 mV	NTC first gear

Table 12 NTC Threshold Selection

*Note that the accuracy of the external resistance should be 1% and the voltage of NTC_MODE should be in the middle of the judgment range.

IP5383 has six built-in NTC functions. By changing the resistance between NTC_MODE PIN and GND, the corresponding NTC function can be set. The functions are as follows:

NTC first gear:

In the charging state, charging stops when the NTC temperature is lower than 0°C (0.55V), normal charging between 0 and 45°C, and charging stops when the NTC temperature is higher than 45°C (0.39V).

In the discharge state, discharge is stopped when the NTC temperature is lower than -20°C (1.39V), normal discharge is between -20°C and 60°C, and the discharge is stopped when the NTC temperature is higher than 60°C (0.24V).

NTC second gear:

In the charging state, charging stops when the NTC temperature is lower than 2°C (0.50V), normal charging between 2°C and 43°C, and charging stops when the NTC temperature is higher than 43°C (0.42V).

In the discharge state, discharge is stopped when the NTC temperature is lower than -10°C (0.86V), normal discharge is between -10°C and 55°C, and the discharge is stopped when the NTC temperature is higher than 55°C (0.28V).

NTC third gear:

In the charging state, charging stops when the NTC temperature is lower than 0°C (0.55V), normal charging between 0 and 45°C, and charging stops when the NTC temperature is higher than 45°C (0.39V).

In the discharge state, discharge is stopped when the NTC temperature is lower than -10°C (0.86V), normal discharge is between -10°C and 55°C, and the discharge is stopped when the NTC temperature is higher than 55°C (0.28V).

NTC fourth gear:

In the charging state, when the NTC temperature is lower than -10°C (0.86V), the charging stops, the current limit of the BAT terminal is 0.2C between -10°C ~0°C, and C is equal to the battery capacity set by FCAP, and the normal charging is between 0°C and 45°C (0.39V). Between 45°C and 55°C, the constant voltage charging voltage is reduced by 0.1V*N to charge the battery with normal current, and the NTC temperature is higher than 55°C (0.28V) to stop charging.

In the discharge state, discharge is stopped when the NTC temperature is lower than -20°C (1.39V), normal discharge is between -20°C and 55°C, and the discharge is stopped when the NTC temperature is higher than 55°C (0.28V).

NTC fifth gear:

In the charging state, when the NTC temperature is lower than 2°C (0.50V), the charging stops, the current limit of the BAT terminal is 0.1C between 2°C and 17°C, and C is equal to the battery capacity set by FCAP, and the normal charging is between 17 and 43°C (0.42V). and the NTC temperature is higher than 43°C to stop charging.

In the discharge state, discharge is stopped when the NTC temperature is lower than -20°C (1.39V), normal discharge is between -20°C and 60°C, and the discharge is stopped when the NTC temperature is higher than 60°C (0.24V).

NTC sixth gear:

In the charging state, When the NTC temperature is lower than -10°C (0.86V), the charging stops, the current limit of the BAT terminal is 0.2C between -10°C and 0°C (0.55V), and the charging is normal between 0 °C and 45°C. the BAT terminal current is limited to 0.2C for charging between 45°C ~55°C (0.28V), C is equal to the battery capacity set by FCAP, and the NTC temperature is higher than 55°C (0.28V) to stop charging.

In the discharge state, discharge is stopped when the NTC temperature is lower than -20°C (1.39V), normal discharge is between -20°C and 55°C, and the discharge is stopped when the NTC temperature is higher than 55°C (0.28V).

*Note:

- (1) After detecting the abnormal temperature of the NTC, it resumes normal operation when the temperature is ± 5 degrees Celsius of the protection temperature. In the brackets after the

above temperature, the NTC PIN voltage corresponding to the temperature is written. The calculation method is: the current discharged by the NTC PIN * the NTC resistance value at the temperature.

- (2) The NTC resistance parameter referenced in the above temperature range is $10\text{k}\Omega@25^{\circ}\text{C}$ $B=3380$. Other models are different and need to be adjusted. If the scheme does not require NTC, the NTC pin should be connected to the ground with a $10\text{k}\Omega$ resistor, and cannot be left floating or grounded directly.

***Note:**

The above function PIN selection resistor instructions are all PIN selection for LED models on the demo. Please refer to the specific schematic diagram for PIN selection for other model functions.

13 Layout considerations

13.1 VIO and BAT Terminal Sampling Lines

In the schematic diagram, BAT and CSP2 belong to the same network, but they must go to the 5mΩ sampling resistor end respectively when routing. Similarly, CSN2 and PCON also need to go to the 5mΩ sampling resistor end respectively.

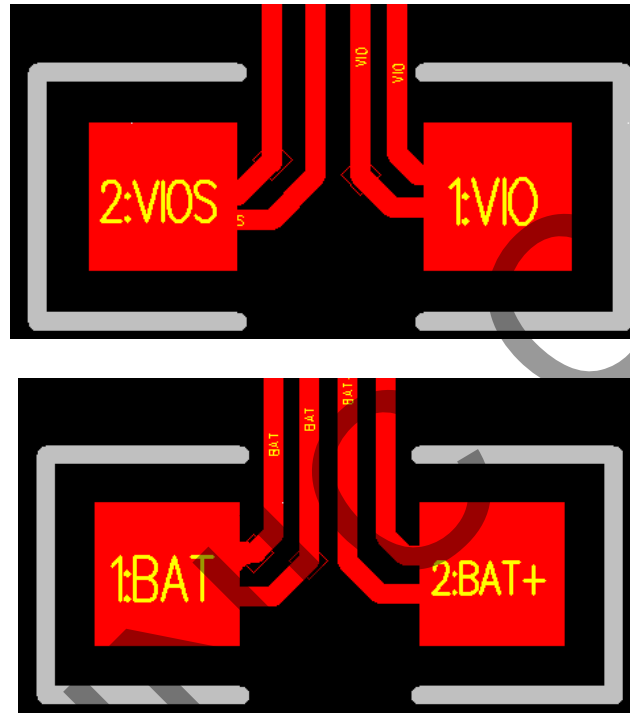

Figure 20 5mΩ Resistance Sampling Line

13.2 The VIO and BAT capacitors need to be close to the sampling resistor, and the GND of the capacitor needs to be close to the PGND of the H-bridge

Place at least one 22 μ F capacitor next to the 5m Ω sampling resistor of VIOS and BAT. The GND of the capacitor must be close to the GND of the H-bridge power MOSFET, and more vias need to be added between the capacitor GND and the H-bridge power MOSFET GND. Otherwise, it may cause interference to current sampling and system stability.

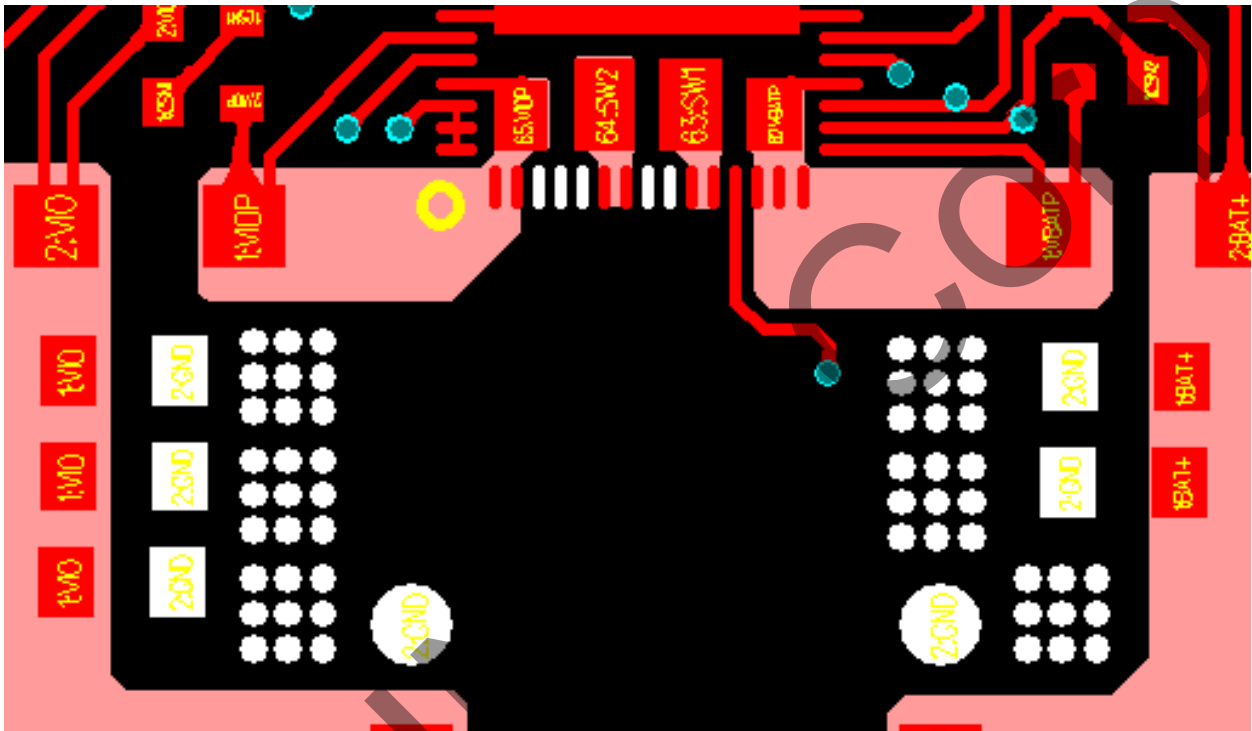

Figure 21 The VIOS and BAT capacitors are close to the sampling resistor

13.3 VCCIO capacitors and VCC5V capacitors need to be placed near the chip pins

VCCIO capacitors and VCC5V capacitors need to be placed near the chip pins, and additional vias need to be added near the capacitor GND

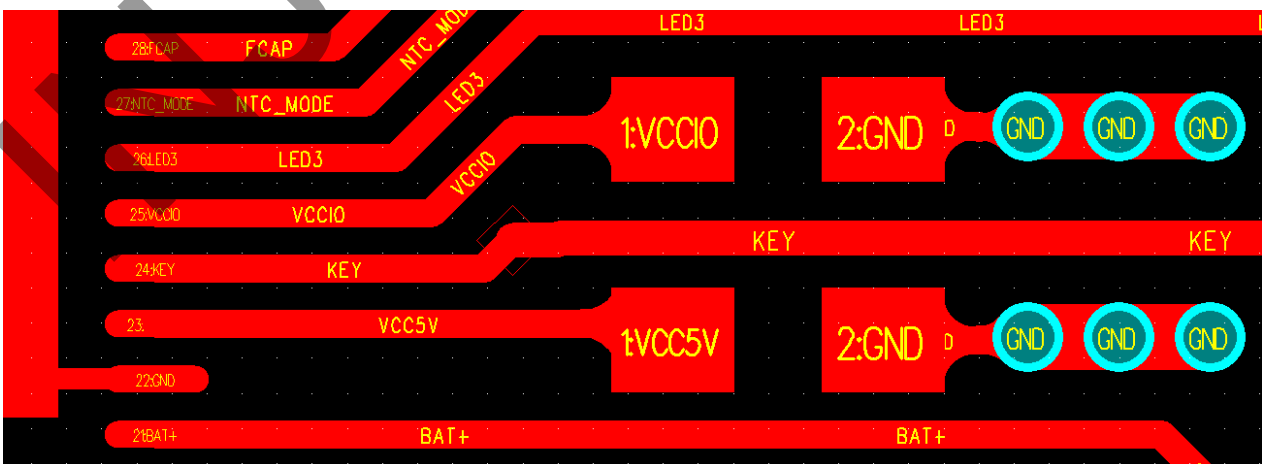

Figure 22 PGND and system GND form a smooth loop and power path through copper foil

13.4 The Wiring from VIO to MOSFET of output USB-A1, USB-C1 and USB-C2

The wiring from VIO to USB-A1, USB-C1 and USB-C2 output MOSFET needs to be routed separately at the VIO of the VBUS_I resistor, otherwise it may affect the automatic recovery fast charging function when multi-port to single-port.

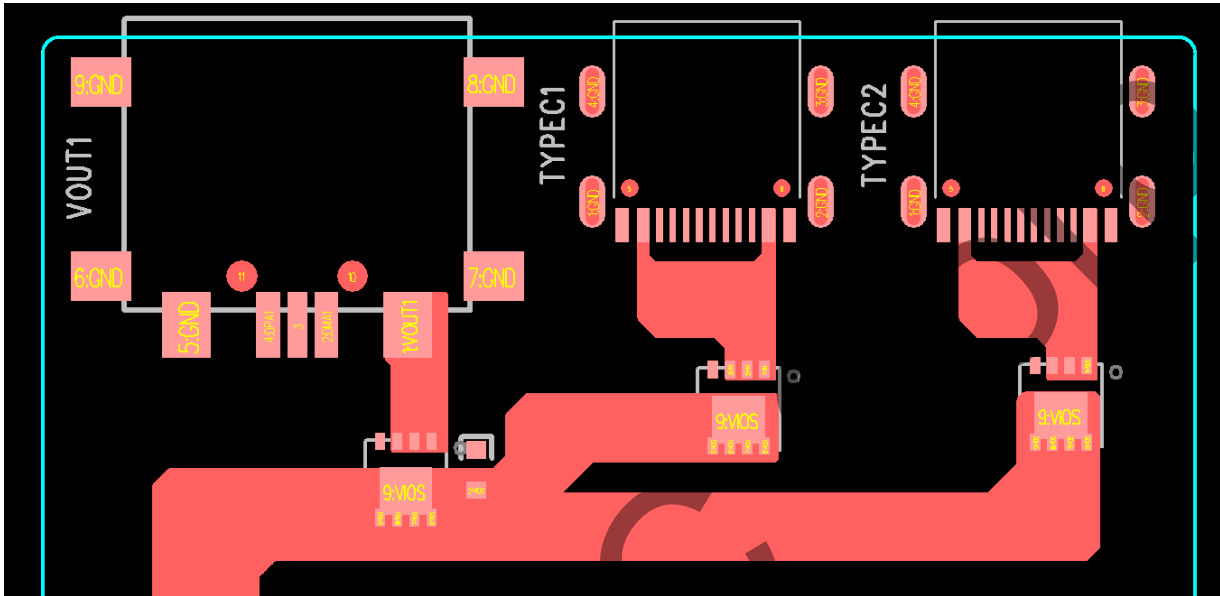

Figure 23 Route The VIO To Each Output Port

13.5 VBAT, VIO, and CSP near the IC pins require the addition of a 0.1uF capacitor

VBAT, VIO, and CSP near the IC pins require the addition of a 0.1uF capacitor, otherwise it will affect the accuracy of current ADC sampling, thereby affecting the function of the power meter and current limiting.

14 Application Schematic

14.1 Application Schematic Diagram of LED Lamp Scheme

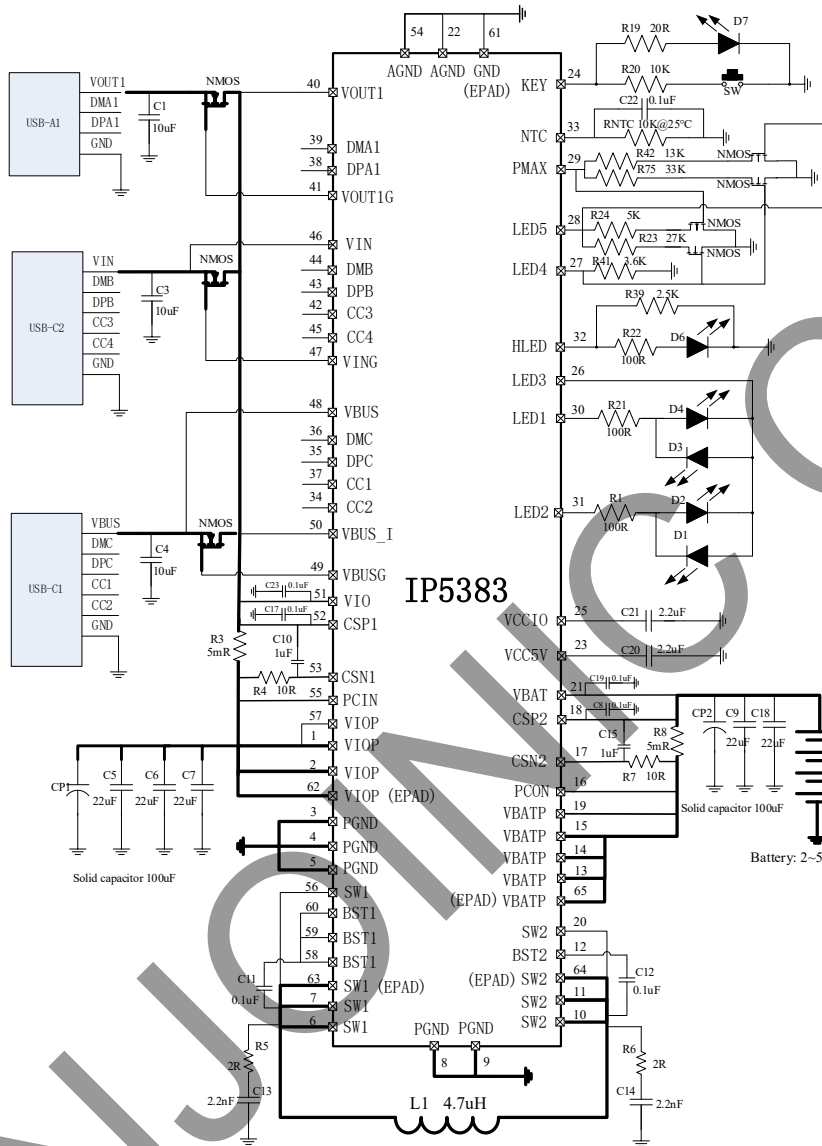

R42	Maximum Input Power	Maximum Output Power
33kΩ	45W	45W
27kΩ	30W	45W
18kΩ	35W	35W
13kΩ	30W	30W
9.1kΩ	30W (maximum input voltage 15V)	30W
6.2kΩ	30W (maximum input voltage 15V)	30W (maximum output voltage 15V)
3.6kΩ	20W	30W

R41	NTC.MODE
27kΩ	NTC gear 6
18kΩ	NTC gear 5
13kΩ	NTC gear 4
9.1kΩ	NTC gear 3
6.2kΩ	NTC gear 2
3.6kΩ	NTC gear 1

R39	Corresponding series of battery cells set
10kΩ	5
7.5kΩ	4
5kΩ	3
2.5kΩ	2

R24	Corresponding capacity of battery cells set
5kΩ	5000mAh
10kΩ	10000mAh
15kΩ	15000mAh
20kΩ	20000mAh
25kΩ	25000mAh
30kΩ	30000mAh

R23	Corresponding type of battery
27kΩ	4.2V
18kΩ	4.3V
13kΩ	4.35V
9.1kΩ	4.4V
6.2kΩ	4.15V
3.6kΩ	3.65V (Lithium iron phosphate battery)

R75	Corresponding intelligent temperature selection
33kΩ	110°C
27kΩ	100°C
18kΩ	95°C
13kΩ	90°C
9.1kΩ	85°C
6.2kΩ	80°C
3.6kΩ	70°C

Figure 24 IP5383 LED Scheme Application Schematic Diagram

14.2 Digital Tube Solution Application Schematic Diagram

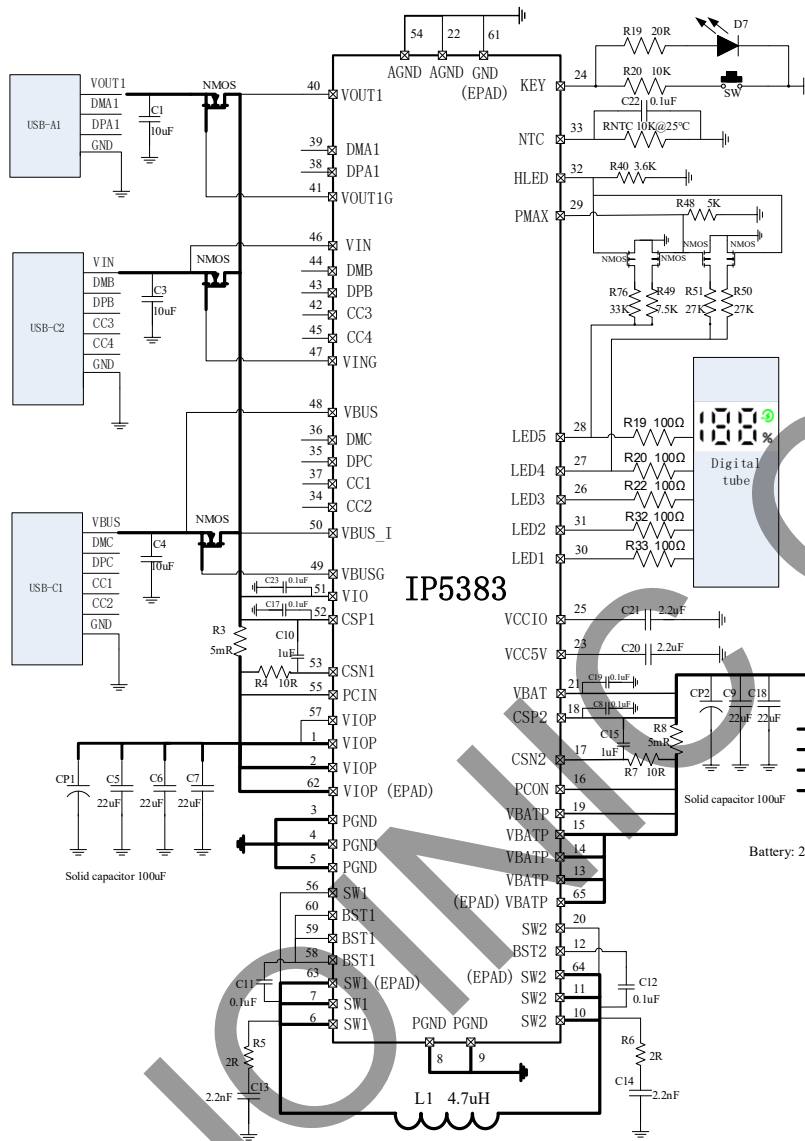

R51	Maximum Input Power	Maximum Output Power
33kΩ	45W	45W
27kΩ	30W	45W
18kΩ	35W	35W
13kΩ	30W	30W
9.1kΩ	30W (maximum input voltage 15V)	30W
6.2kΩ	30W (maximum input voltage 15V)	30W (maximum output voltage 15V)
3.6kΩ	20W	30W
R40	NTC MODE	
27kΩ	NTC gear 6	
18kΩ	NTC gear 5	
13kΩ	NTC gear 4	
9.1kΩ	NTC gear 3	
6.2kΩ	NTC gear 2	
3.6kΩ	NTC gear 1	
R49	Corresponding series of battery cells set	
10kΩ	5	
7.5kΩ	4	
5kΩ	3	
2.5kΩ	2	
R48	Corresponding capacity of battery cells set	
5kΩ	5000mAh	
10kΩ	10000mAh	
15kΩ	15000mAh	
20kΩ	20000mAh	
25kΩ	25000mAh	
30kΩ	30000mAh	
R50	Corresponding type of battery	
27kΩ	4.2V	
18kΩ	4.3V	
13kΩ	4.35V	
9.1kΩ	4.4V	
6.2kΩ	4.15V	
3.6kΩ	3.65V (Lithium iron phosphate battery)	
R76	Corresponding intelligent temperature selection	
33kΩ	110°C	
27kΩ	100°C	
18kΩ	95°C	
13kΩ	90°C	
9.1kΩ	85°C	
6.2kΩ	80°C	
3.6kΩ	70°C	

Figure 25 IP5383 Digital Tube Solution Application Schematic Diagram

BOM

Serial No.	Part name	Type	Location	Number	Remarks
1	SMT IC	QFN60 IP5383	U2	1	
2	SMT capacitor	0603 0.1 μ F 10% 50V	C2, C11, C12, C16, C19, C22, C23	7	
3	SMT capacitor	0603 1 μ F 10% 16V	C10 C15	2	
4	SMT capacitor	0603 2.2 μ F 10% 16V	C20 C21	2	
5	SMT capacitor	0603 10 μ F 10% 25V	C1 C3 C4	3	
6	SMT capacitor	0805 22 μ F 10% 25V	C5 C6 C7 C9 C18	5	
7	SMT capacitor	0603 2.2nF 10% 50V	C13 C14	2	
8	SPAEC capacitor	100 μ F 35V 10%	CP1 CP2	2	
9	Inductor	4.7 μ H SPA1265-4R7 RDC<0.01R	L1	1	
10	SMT resistor	0603 0 Ω 1%	R17 R18 R36	3	
11	SMT resistor	0603 10 Ω 1%	R4 R7	2	
12	SMT resistor	0603 2 Ω 1%	R2 R11 R28	3	
13	SMT resistor	1206 0.005 Ω 1%	R3 R8	2	ppm<75
14	SMT resistor	0603 5k Ω 1%	R24	1	FCAP
15	SMT resistor	0603 2.5k Ω 1%	R39	1	Series of battery
16	SMT resistor	0603 27k Ω 1%	R23	1	Type of battery
17	SMT MOSFET	2N7002	N1 N5 N9 N10	4	
18	SMT resistor	0603 33k Ω 1%	R75	1	Intelligent temperature selection
19	SMT resistor	0603 13k Ω 1%	R42	1	PMAX
20	SMT resistor	0603 3.6k Ω 1%	R41	1	NTC MODE
21	SMT capacitor	0603 0.1 μ F 10% 50V	C22	1	NTC circuit
22	NTC thermal resistor	10k Ω @25 $^{\circ}$ C B=3380	RNTC	1	
23	SMT resistor	0603 100 Ω 1%	R1 R21 R22	3	LED scheme selection
24	SMT LED	0603 blue	D1 D2 D3 D4	4	
25	SMT LED	0603 red	D6	1	
26	Digital tube	YFTD1508SWPG-5D	SMG1	1	digital tube scheme selection
27	SMT resistor	0603 100 Ω 1%	R21 R22 R23 R24 R25	5	LED scheme selection
28	LED	5MM LED	D7	1	lighting circuit
29	SMT resistor	0603 20 Ω 1%	R19	1	
30	SMT resistor	0603 10k Ω 1%	R20	1	Key circuit
31	KEY	SMT 3*6	SW	1	
32	SMT MOSFET	R _{DS} <15m Ω , V _{DS} >30V, V _{GS} >12V, I _D >10AF	U2 U4 U6	3	
33	Output USB-A	AF10 8 pin USB	USB-A	1	
34	USB-C connector	USB-C connector	USB1 USB2	2	

15 Package

15.1 Package of the Chip

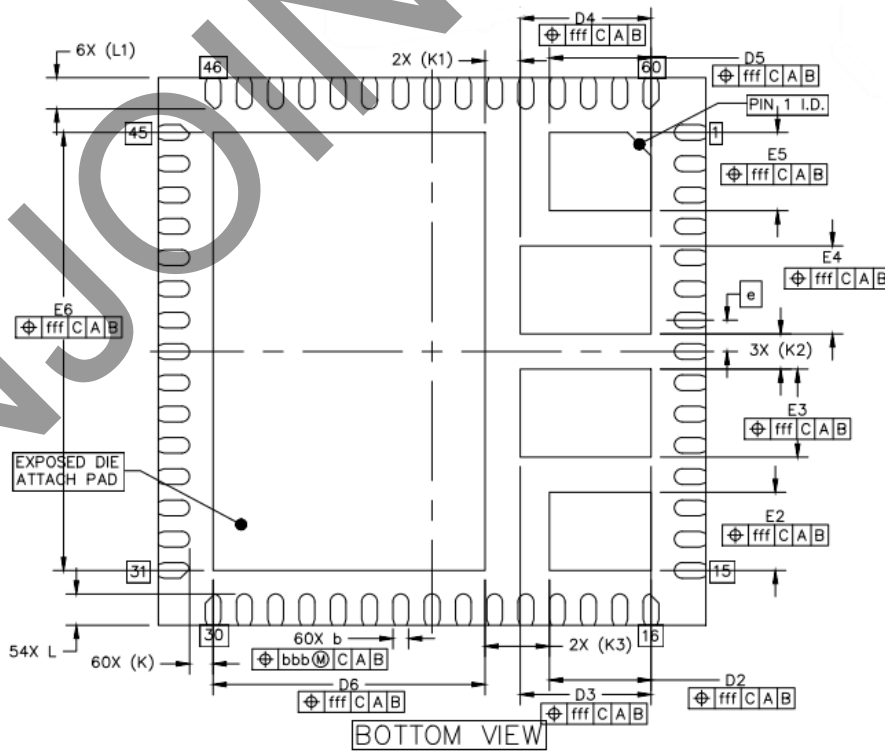
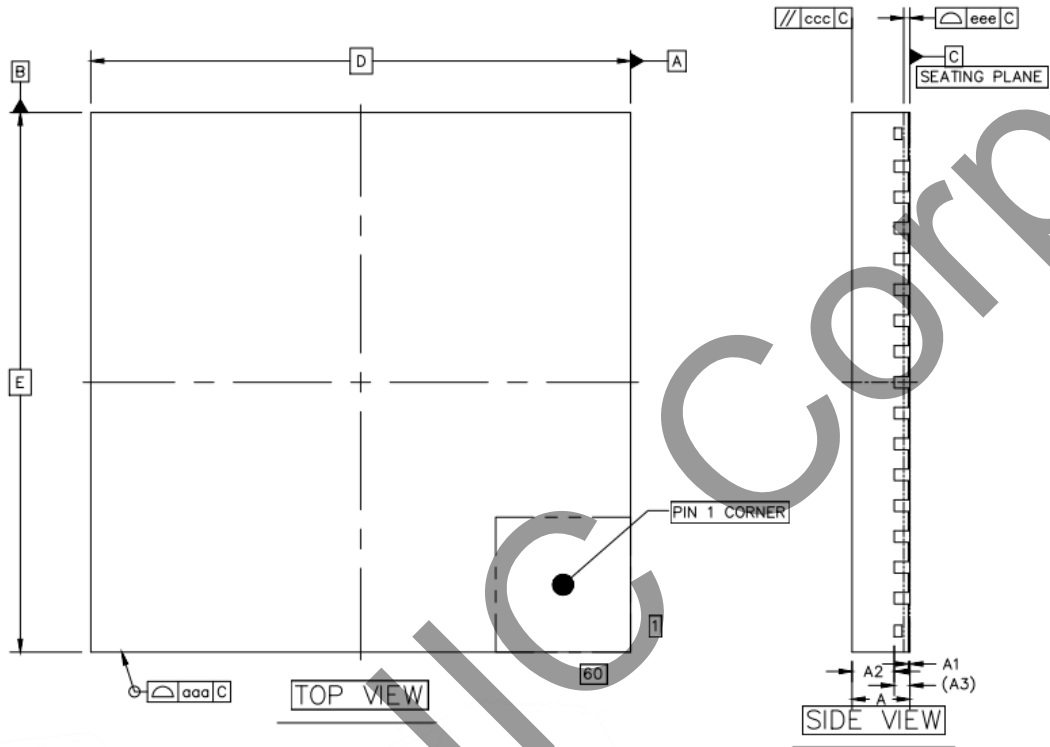

		SYMBOL	MIN	NOM	MAX	
TOTAL THICKNESS		A	0.7	0.75	0.8	
STAND OFF		A1	0	0.02	0.05	
MOLD THICKNESS		A2	---	0.55	---	
L/F THICKNESS		A3	0.203 REF			
LEAD WIDTH		b	0.15	0.2	0.25	
BODY SIZE	X	D	7 BSC			
	Y	E	7 BSC			
LEAD PITCH		e	0.4 BSC			
EP SIZE	X	D2	1.2	1.3	1.4	
	Y	E2	0.9	1	1.1	
	X	D3	1.572	1.672	1.772	
	Y	E3	1.025	1.125	1.225	
	X	D4	1.572	1.672	1.772	
	Y	E4	1.025	1.125	1.225	
	X	D5	1.2	1.3	1.4	
	Y	E5	0.9	1	1.1	
	X	D6	3.378	3.478	3.578	
	Y	E6	5.5	5.6	5.7	
	LEAD LENGTH		L	0.3	0.4	0.5
			L1	0.4 REF		
LEAD TIP TO EXPOSED PAD EDGE		K	0.3 REF			
		K1	0.45 REF			
EXPOSED PAD EDGE TO EXPOSED PAD EDGE		K2	0.45 REF			
		K3	0.822 REF			
PACKAGE EDGE TOLERANCE		aaa	0.1			
MOLD FLATNESS		ccc	0.1			
COPLANARITY		eee	0.08			
LEAD OFFSET		bbb	0.07			
EXPOSED PAD OFFSET		fff	0.1			

15.2 Marking Description



Instructions:



1.  --Injoinic Logo
2. IP5383 --Product Model
3. XXXXXXXX --Manufacture Number
4.  --Pin1 Location

Figure 26 Silk Screen Printing

16 Important Notice

INJOINIC TECHNOLOGY Corp. and its subsidiaries reserve the right to make corrections, enhancements, improvements and other changes to its semiconductor products and services. Buyers should obtain the latest relevant information before placing orders and should verify that such information is current and complete. All semiconductor products (also referred to herein as “components”) are sold subject to INJOINIC TECHNOLOGY Corp.'s terms and conditions of sale supplied at the time of order acknowledgment.

INJOINIC TECHNOLOGY Corp. assumes no liability for applications assistance or the design of Buyers' products. Buyers are responsible for their products and applications using INJOINIC's components. To minimize the risks associated with Buyers' products and applications, Buyers should provide adequate design and operating safeguards.

Buyer acknowledges and agrees that it is solely responsible for compliance with all legal, regulatory and safety related requirements concerning its products, and any use of INJOINIC's components in its applications, notwithstanding any applications-related information or support that may be provided by INJOINIC. Buyer represents and agrees that it has all the necessary expertise to create and implement safeguards which anticipate dangerous consequences of failures, monitor failures and their consequences, lessen the likelihood of failures that might cause harm and take appropriate remedial actions. Buyer will fully indemnify INJOINIC TECHNOLOGY and its representatives against any damages arising out of the use of any INJOINIC's components in safety-critical applications.

Reproduction of significant portions of INJOINIC's information in INJOINIC's data books or data sheets is permissible only if reproduction is without alteration and is accompanied by all associated warranties, conditions, limitations, and notices. INJOINIC TECHNOLOGY Corp. is not responsible or liable for such altered documentation. Copying information from third parties may be subject to additional restrictions.

INJOINIC will update this document from time to time. The actual parameters of the product may vary due to different models or other items. This document is not a warranty of any kind, express or implied.

Resale of INJOINIC's components or services with statements different from or beyond the parameters stated by INJOINIC for that component or service voids all express and any implied warranties for the associated INJOINIC's component or service and is an unfair and deceptive business practice. INJOINIC TECHNOLOGY Corp. is not responsible or liable for any such statements.